

AVIOTEC 8000i IR

Firmware 8.81

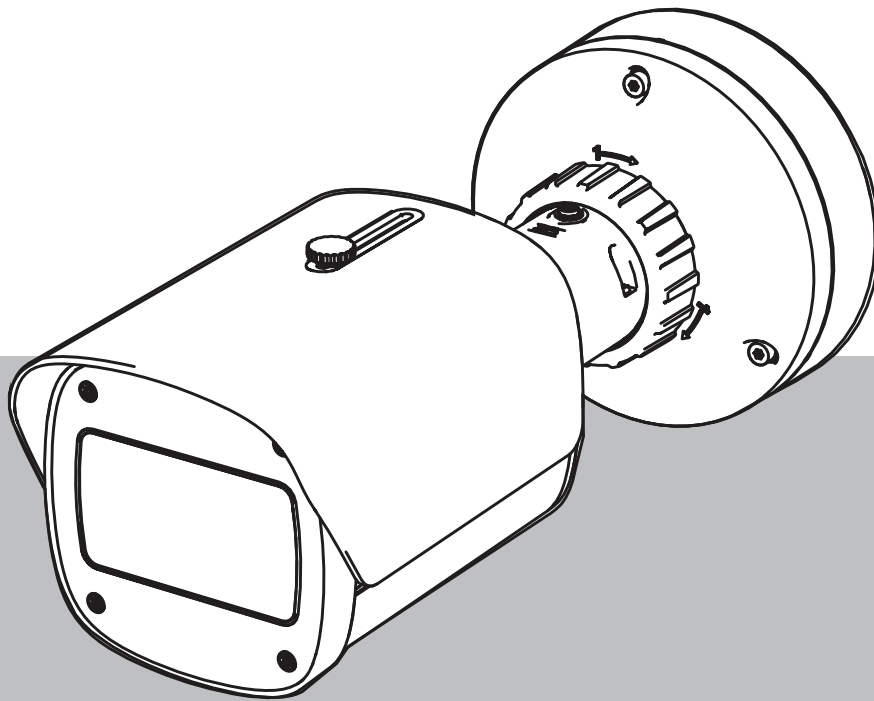

Table of contents

1	Safety instructions	5
1.1	<i>General safety messages / Notices</i>	5
2	Introduction	8
2.1	<i>Disclaimer</i>	8
2.2	<i>About this manual</i>	8
2.3	<i>Conventions in this manual</i>	8
2.4	<i>Definition of optical terms</i>	9
2.4.1	<i>Illumination</i>	9
2.4.2	<i>Focal length</i>	9
2.4.3	<i>Monitoring area</i>	11
2.4.4	<i>Different angle types</i>	11
3	System overview	15
3.1	<i>Camera</i>	15
3.1.1	<i>Power supply</i>	15
3.1.2	<i>Uninterruptible Power Supply</i>	17
3.2	<i>Algorithm</i>	19
3.2.1	<i>Flame detection characteristics</i>	19
3.2.2	<i>Smoke detection characteristics</i>	20
3.2.3	<i>Tamper detection</i>	23
3.3	<i>Video Management System</i>	24
4	Planning	25
4.1	<i>Application basics of video-based fire detection</i>	25
4.1.1	<i>Protection objective - Area monitoring</i>	25
4.1.2	<i>Protection objective - Area-Of-Interest</i>	25
4.2	<i>Flame/smoke sizes (50/75 cm)</i>	25
4.3	<i>Check list</i>	25
4.4	<i>Influencing factors at the installation site (indoor)</i>	26
4.5	<i>Influencing factors at the installation site (outdoor)</i>	32
4.6	<i>Minimum distances</i>	34
4.6.1	<i>Indoor</i>	34
4.6.2	<i>Outdoor</i>	35
4.7	<i>Maximum distances</i>	35
4.7.1	<i>Indoor</i>	35
4.7.2	<i>Outdoor</i>	37
4.8	<i>Immediate environment of the camera</i>	37
4.8.1	<i>Illumination and brightness</i>	37
4.8.2	<i>Infrared (IR) illumination</i>	38
4.8.3	<i>Privacy protection</i>	38
5	Camera integration	39
5.1	<i>Local Area Network</i>	40
5.2	<i>Local Area Network with recording solution</i>	42
5.3	<i>Monitoring Center</i>	43
5.4	<i>Fire Alarm Control Panel</i>	45
5.5	<i>Mobile Devices</i>	46
6	Use cases	48
6.1	<i>Fire detection only</i>	48
6.2	<i>Fire detection profiles</i>	48
6.3	<i>Scheduled fire detection</i>	48

6.4	<i>External trigger to switch fire detection mode</i>	48
7	Technical data	49
8	Troubleshooting	50
8.1	<i>False Alarms</i>	50
8.1.1	<i>False alarms under 4 seconds concerning the whole detection area</i>	50
8.1.2	<i>False alarms at small constant areas</i>	50
8.1.3	<i>Vibrations at the camera site</i>	50
8.2	<i>No alarm transmission</i>	50
8.3	<i>No fire detection</i>	51
8.4	<i>Image quality</i>	51
8.5	<i>Camera</i>	51
9	Appendices	53
9.1	<i>Flame detection</i>	53
9.2	<i>Smoke detection</i>	55

1 Safety instructions

**Danger!**

Indicates a hazardous situation which, if not avoided, will result in death or serious injury.

**Warning!**

Indicates a hazardous situation which, if not avoided, could result in death or serious injury.

**Caution!**

Indicates a hazardous situation which, if not avoided, could result in minor or moderate injury.

**Notice!**

Indicates a situation which, if not avoided, could result in damage to the equipment or environment, or data loss.

1.1 General safety messages / Notices

**Notice!**

Video-based fire detection sets camera settings to a specific preset. Setting of the image parameters can be changed only to a limited extent.

**Notice!**

Respect data protection.
The relevant data protection and privacy rules are to be complied with.

**Notice!**

Reduced detection distances at image margin area.
Due to optical distortion of the lens, the maximum detection distances at the image margin area are reduced.

**Caution!**

Make sure to test the fire detection after updating to the latest firmware.

**Notice!**

Minimum Illumination required.
To enable the proper functioning of the video-based fire detection algorithm, a minimal illumination of 1 lx is required. If the illumination is less than 1 lx, the internal or additional IR illumination is required.

**Notice!**

No detection of moving fire.
Moving fires might not be detected by the video-based fire detection. An example of a moving fire is a fire on a moving conveyor belt.

**Notice!**

Ensure that you are always using the latest version of the documentation and the current camera firmware. The manufacturer will not be held liable for any damages resulting from the use of older versions. Refer to: <https://www.boschsecurity.com>

**Notice!**

No direct connection to fire services in EN54 compliant installations.
Authorities can allow a connection to fire services after verifying alarms in a monitoring center. Exceptions are possible due to local regulations.

**Notice!**

Avoid obstructions in the field of view!
Covered fires cannot be detected correctly. An unobstructed view of the detection area is necessary.

**Notice!**

Bright strongly illuminated areas in the background (e.g., white areas, sun or sky) limit the detection of flames or can lead to flames not being detected.

**Notice!**

Flame-colored background in the picture is to be avoided, since a reliable detection cannot be ensured!

**Notice!**

Qualified personnel only.
Assembly and installation must only be performed by qualified personnel.

**Caution!**

The Low Voltage power supply unit must comply with EN/UL 60950. The power supply must be a SELV-LPS unit or a SELV - Class 2 unit (Safety Extra Low Voltage - Limited Power Source).

**Caution!**

Installation should only be performed by qualified service personnel in accordance with the National Electrical Code (NEC 800 CEC Section 60) or applicable local codes.

**Notice!**

Optimized smoke detection.
The video-based fire detection algorithm is optimized for smoke of smoldering fires.

**Notice!**

Make sure the camera is firmly mounted.
Camera shake might lead to non-detection. Avoid vibrations of the camera and the camera environment.

**Notice!**

Influencing factor wind conditions
Strong air currents can cause false alarms by raising dust or debris similar in appearance to fire and smoke.

**Warning!**

Bosch Security Systems assumes no liability for the reliability of fire detection in case of configuration changes in Expert Mode. This means it is your responsibility to ensure the reliability of the fire detection and, if necessary, fire tests.

**Notice!**

Avoid image regions with continuous upward motion.
Continuous upward motion might lead to false alarms.

**Notice!**

No detection in blinking light regions in the detection area.

**Notice!**

Make sure that the network performance is high enough to provide the video/live image to an operator in sufficient quality for verification.

**Notice!**

The camera must be mounted horizontally. A twisted installation, e.g. 90° or 270° is not permissible.

**Notice!**

The video-based fire detection system can only detect events within its field of view.

**Notice!**

Weather influences, such as fog, snow, rain, can adversely affect the detection performance.

2 Introduction

2.1 Disclaimer

IMPORTANT: Video fire indication systems are video content analysis systems. They give indications for possible fires and are designed to supplement fire detection systems and human guards in monitoring centers in order to recognize possible dangerous situations. Video fire indication systems are confronted with a higher amount of challenges considering scenery and background compared to conventional fire detection systems. They cannot ensure that fire will be detected reliably in all scenery settings. Thus, the video fire detection system shall be seen as a support system that enhances the probability of early fire detection, with the restriction that it shall not be seen as a system that ensures fire detection in all possible image scenarios and it might detect false alarms. Conventional fire alarm systems must in no way be replaced by video-based fire alarm systems.

In addition, and for the U.S. market only, Bosch Security Systems makes no representation that the video fire indication system will prevent any personal injury or property loss by fire or otherwise; or that such product will in all cases provide adequate warning or protection. Buyer understands that a properly installed and maintained fire indication system may only reduce the risk of a fire or other events occurring without providing an alarm, but it is not insurance or a guarantee that such will not occur or that there will be no personal injury or property loss as a result.

Consequently, Bosch Security Systems shall have no liability for any personal injury, property damage or other loss based on a claim the product failed to give warning.

2.2 About this manual

This manual has been compiled with great care and the information it contains has been thoroughly verified. The text was correct at the time of publication, however, the content can change without notice. Bosch Security Systems accepts no liability for damage resulting directly or indirectly from faults, incompleteness or discrepancies between this manual and the product described.

All hardware and software product names used in this document are likely to be registered trademarks and must be treated accordingly.

Copyright

This manual is the intellectual property of Bosch Security Systems and is protected by copyright.

All rights reserved.

2.3 Conventions in this manual

Terms concerning the adjustment of the smoke and flame algorithm, such as menu options, commands or text in the user interface, are written in bold.

2.4 Definition of optical terms

2.4.1 Illumination

Dynamic range

The dynamic range is the ratio between the darkest spot compared to the lightest spot in the application. Use a luxmeter to determine the brightness in your application. The dynamic range in the camera image / the detection area must be equal or less than factor 1000.

Illumination is an important influencing factor for sensible optical systems. Natural light shows the huge range of illumination values from direct sunlight (~100.000 lx) to full moon on a clear night (~1.0 lx).

The following table provides an overview of typical illumination values in different application areas:

Application Area	Illumination (in lx)
Storage facility	50
Process plants	200
Sales room	300
Office space	500

In general a uniformly illuminated monitoring area is advantageous for the video-based fire detection. Backlight should be avoided.

The illumination is measured using a luxmeter in the application at a height of 1 meter with the sensor pointing vertically upwards.

2.4.2 Focal length

The focal length of an optical system defines the distance between a light refracting lens and the focal point. Field of view, maximum distance and field angle are dependant as shown in the graphic below.

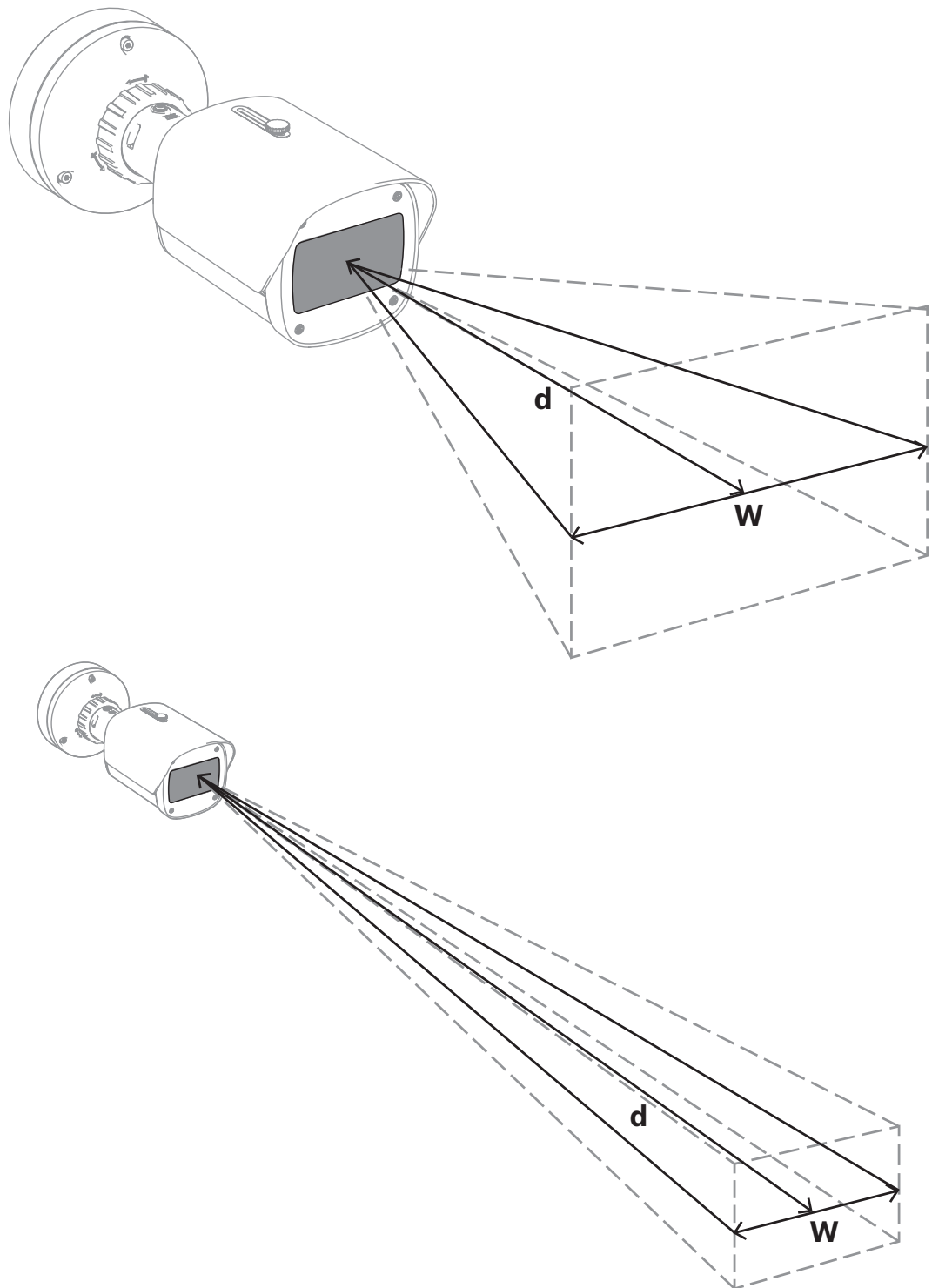

The maximum width of the field of view (w) may be realized by the minimum focal length. This adversely affects the maximum distance (d) to a detectable fire. The maximum distance to a detectable fire may be reached by adjusting the largest focal length which decreases the width of the field of view to the minimum.

2.4.3 Monitoring area

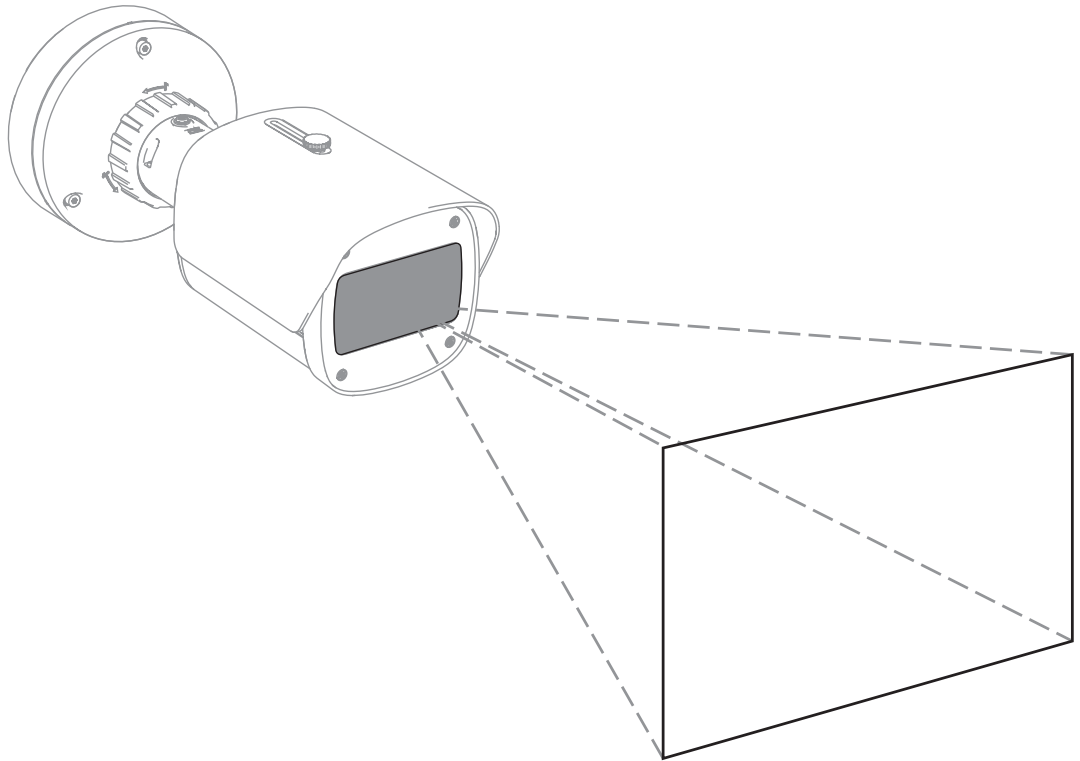

The monitoring area defines the effective space that can be observed by the video-based fire detection. It is depending on the setting of the camera lens.

2.4.4 Different angle types

There are different types of angles influencing the set-up of the camera. The following overview helps to get a better understanding of angles which are important for the video-based fire detection.

Angle between ground and line of sight

The angle between a fire on the ground and the line of sight to the camera is important for the flame and smoke detection. This angle needs to be 40° or less, otherwise flame or smoke will not be detected.

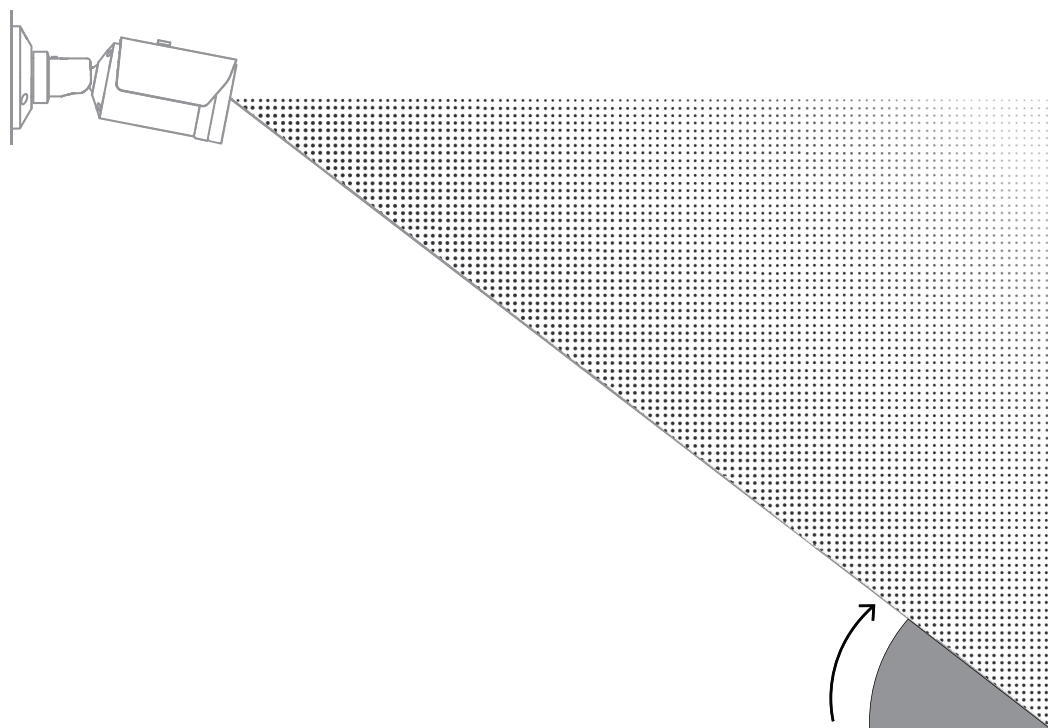
**Opening angle of the lens**

The opening angle of the lens can be set from wide-angle to telephoto setting. This influences the field of view of the camera.

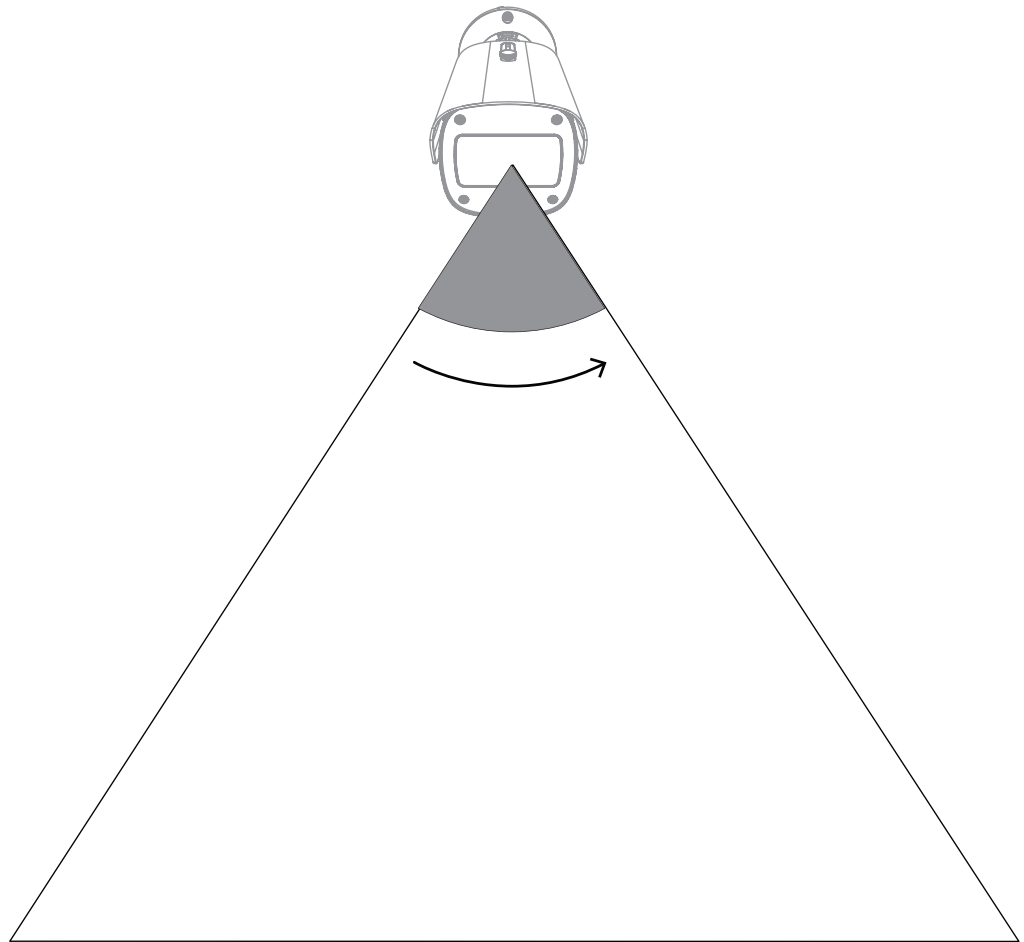

Angle for vertical alignment of the camera

The vertical alignment of the camera is also important for the video-based fire detection. A flat angle is recommended.

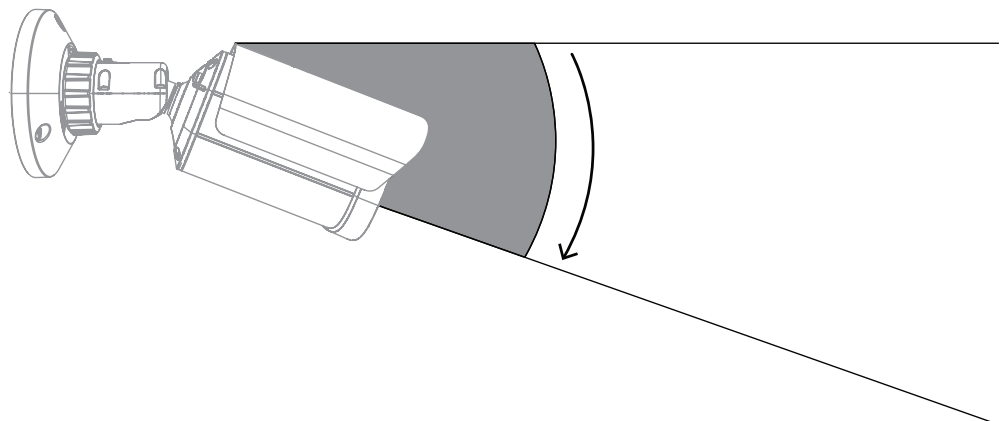

Angle for horizontal alignment of the camera

Align the camera according to your application by adjusting the angle of the horizontal alignment of the camera.

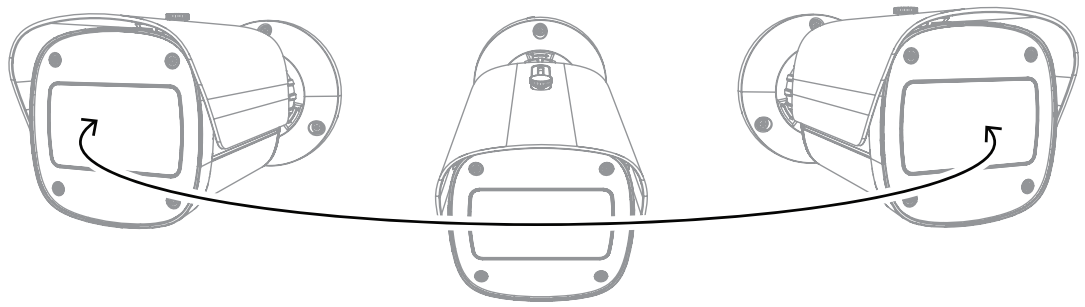

3 System overview

Video-based fire detection is the system of choice when reliable video motion fire detection is needed. Subject to the installation and operating conditions explained in this manual, it can, for example, supplement traditional fire detection systems or provide means of fire detection where traditional fire detection systems are technically limited. AVIOTEC 8000i IR operates as stand-alone unit and doesn't need a separate evaluation unit.

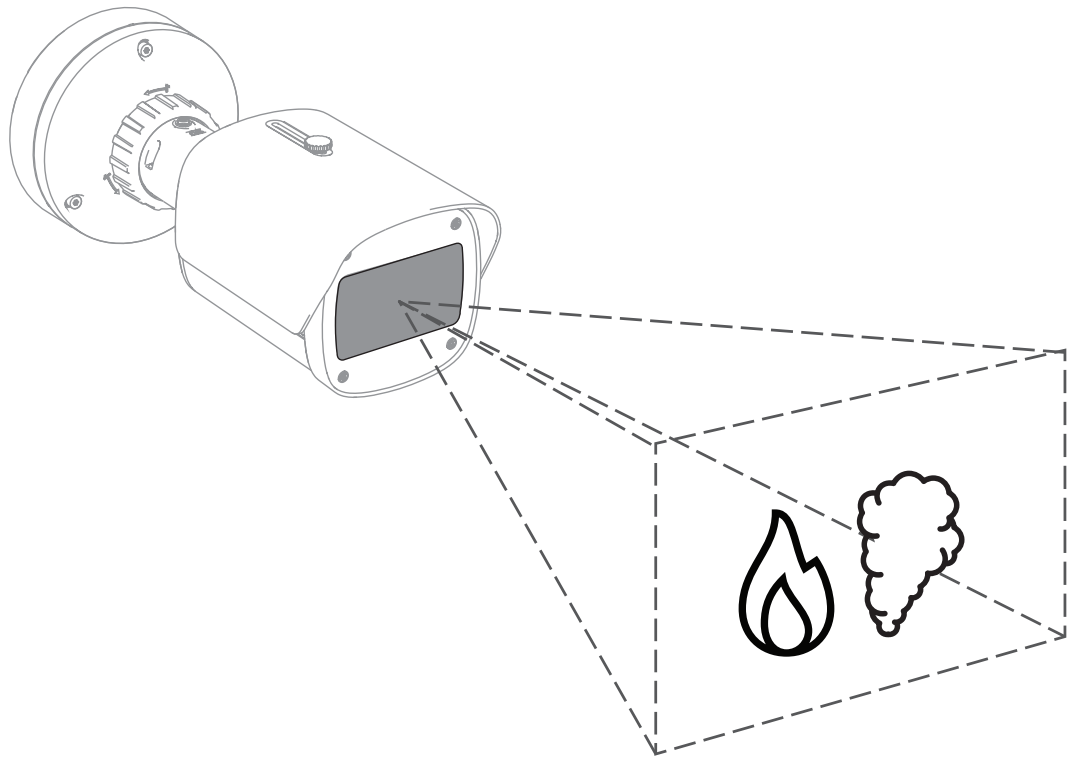

Alarms are shown with a red rectangle in the camera image and are identified with a flame or smoke symbol for differentiation.

3.1 Camera

3.1.1 Power supply



Notice!

Use only Power-over-Ethernet (PoE) approved devices.

AVIOTEC 8000i IR offers you two possible power supplies:

- Power-over-Ethernet (PoE)
- 12-26 VDC/24 VAC input

Power-over-Ethernet (PoE) can be connected at the same time as a power supply. If auxiliary power and PoE is applied simultaneously, the camera selects PoE and shuts off the auxiliary input.

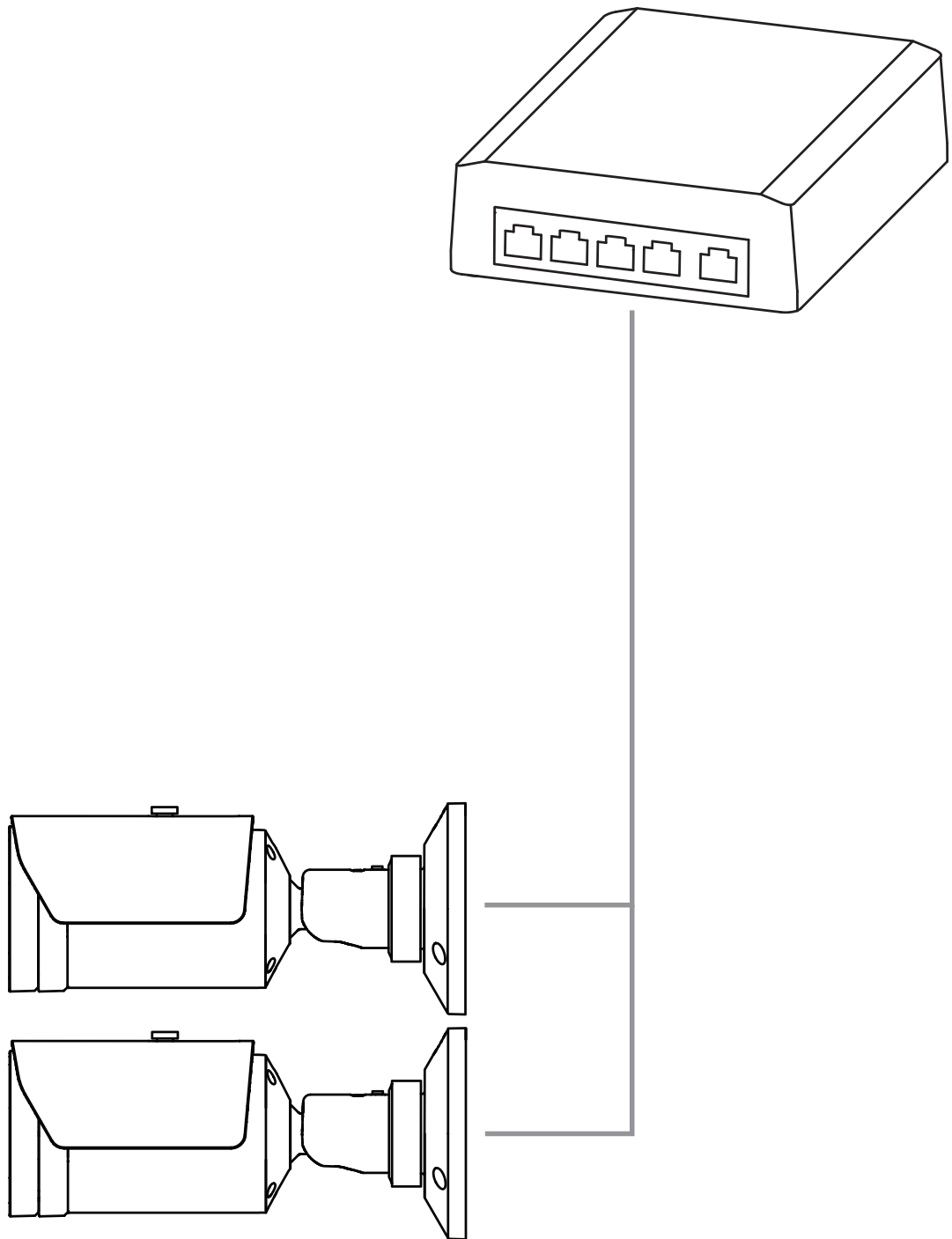

Power-over-Ethernet (PoE) allows to use the Ethernet cabling for data transmission and for supplying power to the network device in the same cable. It is possible to realize long cable lengths in a PoE network system. The standard power supply for the video-based fire detection is Power-over-Ethernet. Alternatively, a 12-26 VDC/24 VAC power supply may be connected.

3.1.2 **Uninterruptible Power Supply**

An uninterruptible power supply allows electronic devices to keep running for a short period of time when the primary power source is lost. In case of an electrical power outage, the video-based fire detection cameras will be supplied by the uninterruptible power supply.

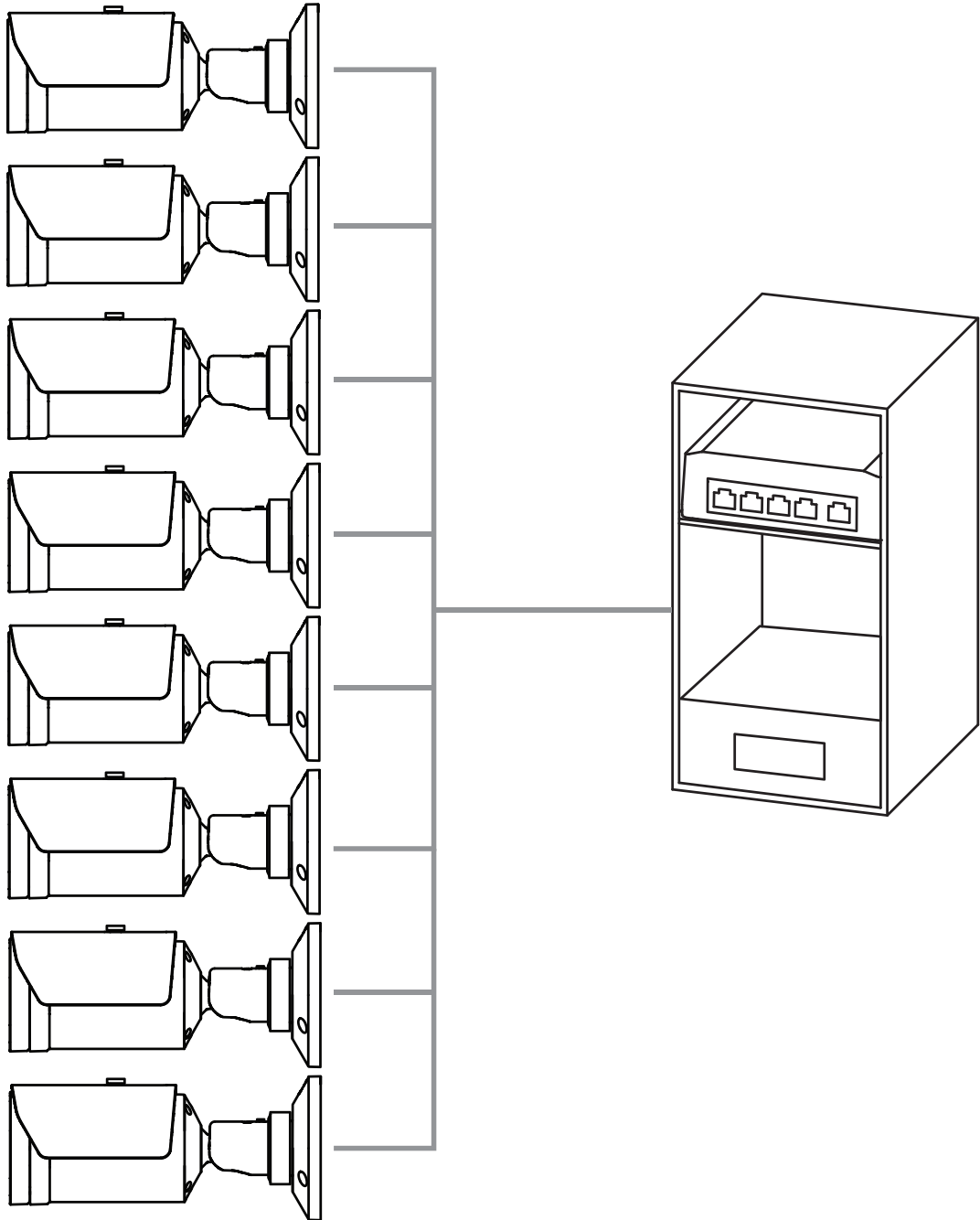

3.2

Algorithm

The smoke and flame algorithm analyzes video frames by means of characteristic spatio-temporal patterns and variables. The core of the detection algorithm is a Deep Learning Network which was trained on a large-scale internal database, which is representative of the use cases of a Video-based Fire Detection System. The fast detection algorithm is based on a real-time image processing on the camera firmware.

There are factors that can influence this kind of visual fire detection. If possible, avoid obstructions in the field of view, as they can have an influence on the detection speed in case of fire. Flames behind obstructions cannot be detected and smoke needs to rise above the obstruction to be detected in the field of view of the camera. In this case it is necessary to analyze whether there is any need for further video-based fire detection cameras.

Division of the field of view into cells

The algorithm divides the image horizontally into 20 and vertically into 12 even grids to analyze the video image. In each grid cell the algorithm decides if there is flame or smoke visible in its area. There is a specific time span until the alarm triggers. This verification time is a global counter: if at least one grid cell is in alarm, the verification time starts counting.

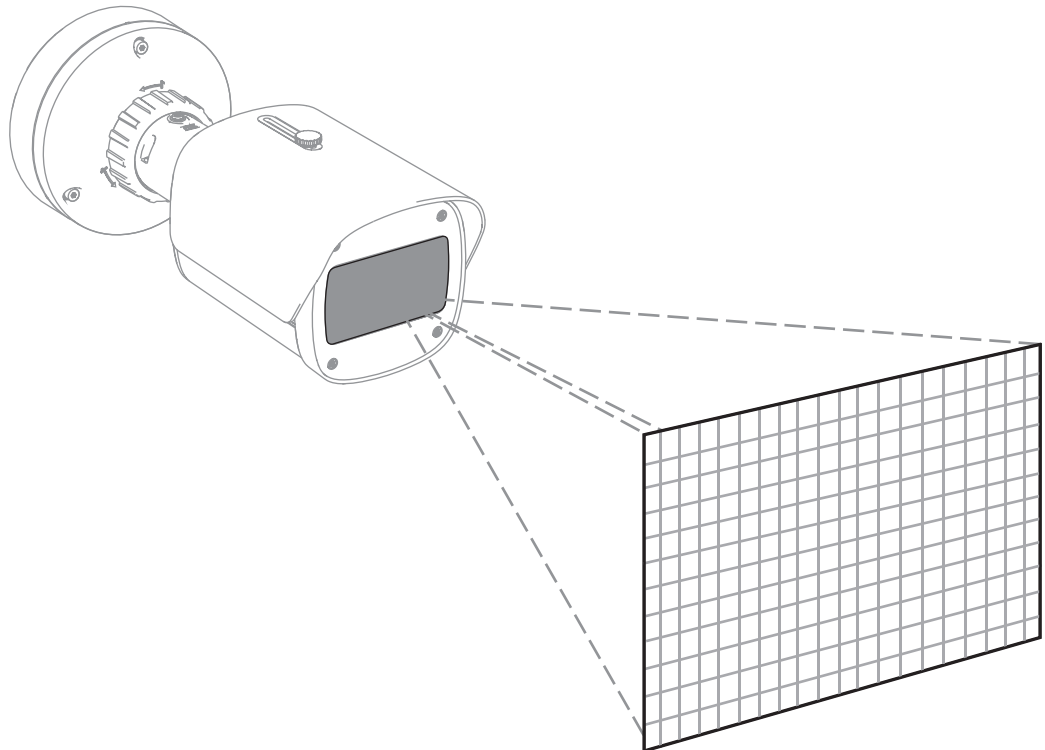

AVIOTEC 8000i IR can be used as primary fire detection system when the application is not covered by any code of practice or other kind of standards or if the necessary approvals/releases have been obtained for the intended applications in accordance with the applicable laws and other regulations.

3.2.1

Flame detection characteristics

The Algorithm analyzes the video stream for potential fire events by searching for typical flame behavior. To be detectable, a flame must be visible in front of the image background. Transparent flames or flames with low luminance, like blue flames might not be detected.

3.2.2 Smoke detection characteristics



Notice!

All smoke detection properties are influenced by wind.

The video stream is analyzed for potential fire events by searching for typical smoke movement and optical appearance of smoke.

The video-based fire detection is optimized for smoke of smoldering fires.

Ambient smoke - smoke which is not moving - might not be detected.

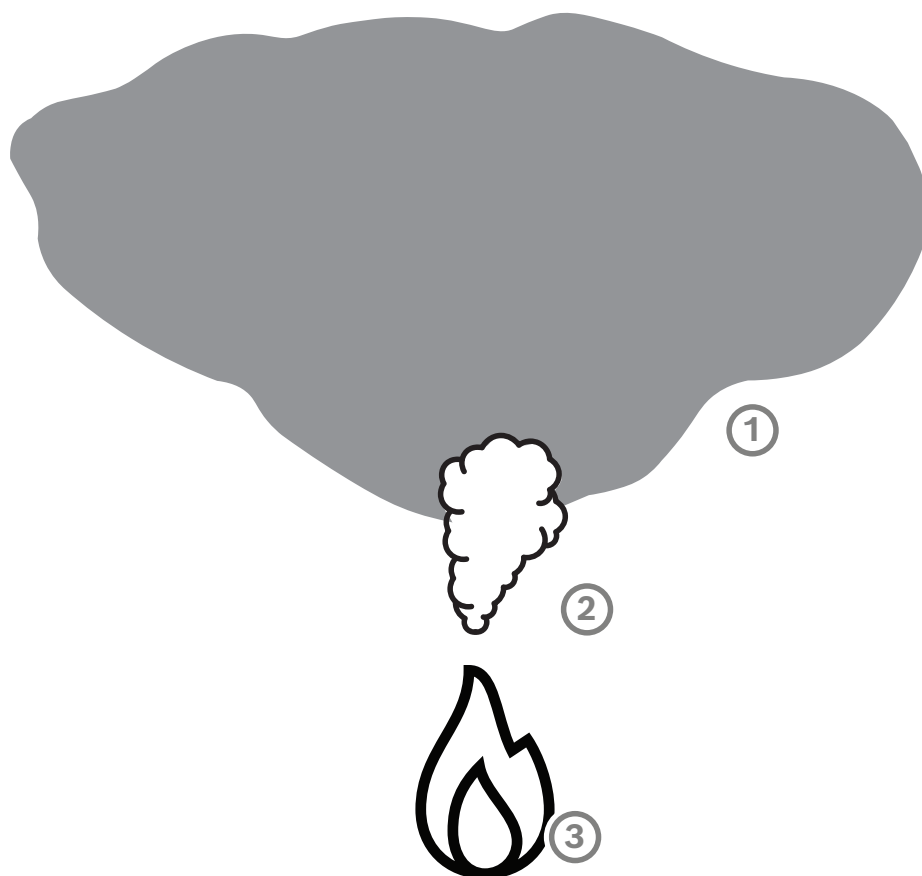

1	Ambient smoke
2	Smoke plume
3	Fire

Minimum and maximum smoke width and motion speed

A minimum speed of smoke is needed together with a minimum width of the smoke plume to be detected by the video-based fire detection. The minimum motion speed of smoke and the minimum width have to be reached at the same location in the smoke plume. The same

applies to the maximum detection speed and maximum width. It is not sufficient to measure one value at the bottom and the other value at the top of the smoke plume (see chapter Technical data).

Direction and angle of a smoke plume

The inclination angle and direction of a smoke plume are important indicators to detect smoke. In the field of view of the camera, moving smoke plumes can have a maximum tilt angle of 90° and will be detected.

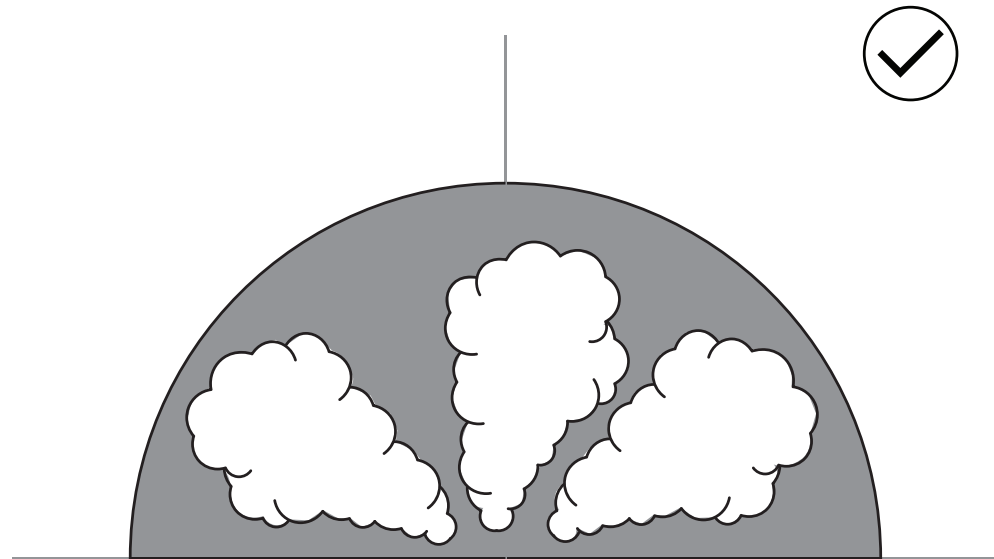

Smoke plumes must be visible in the image to be detected by the video-based fire detection. Smoke plumes moving in the direction of the camera might not be detected as the movement in the visible image of the camera might look like downward movement.

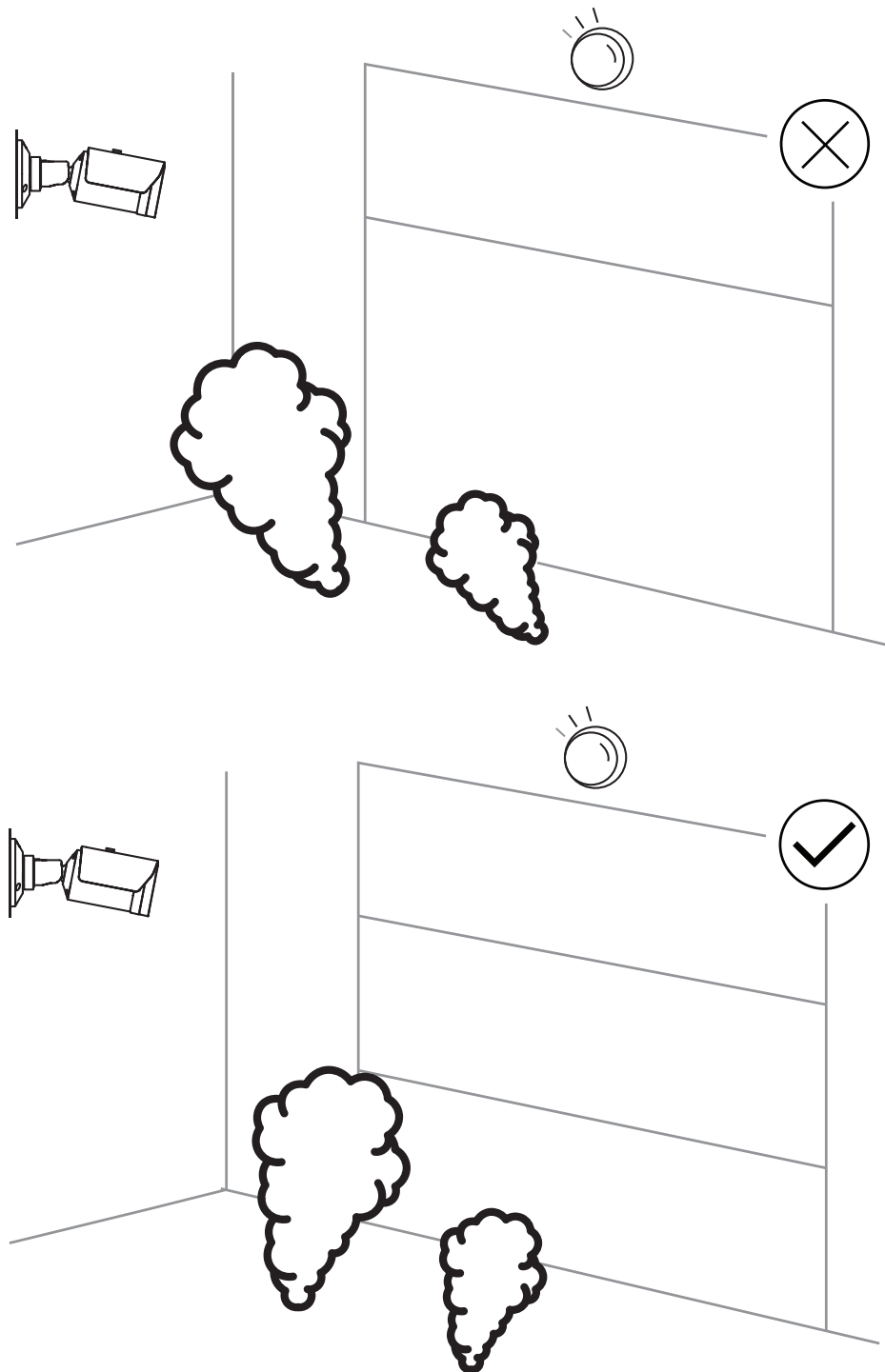

The smoke detection covers a large area of application. Nevertheless, there might be some disruptive factors in the operational environment of the customer. Objects with a similar movement pattern of smoke might cause false alarms, e.g. escalators or conveyor belts. Large fires with rapidly spreading smoke in the direction of the camera may lead to non-detections.

Smoke visibility

The smoke must stand out from the background in the camera image.

3.2.3 Tamper detection



Notice!

Settings for **Tamper detection** are only available in the Configuration Manager and only in VCA profiles Fire #1 and Fire #2.

There are three possibilities to check the proper function of the camera. In case of malfunction a trouble will be triggered by the relay output. The brightness or darkness in the image can be used to check whether a fault is present. Navigate to **VCA > Tamper detection > Scene quality**.

Scene too bright

Activate **Scene too bright** to check whether the camera image is too bright. You can set the brightness under **Threshold**. The default value is 215.

Scene too dark

Activate **Scene too dark** to check whether the camera image is too dark. You can set the darkness under **Threshold**. The default value is 40.

Another way to detect a fault is to create a reference image. The settings for this can be reached under **VCA > Tamper detection > Reference image check**.

Reference image check

A reference image can be set in order to compare the current camera image with the set reference image and thus detect troubles.

- Click on **Set** to store the current video picture as reference image.
- Activate Reference image check.
- Mask areas in the image in which movements are to be expected.

To ensure that the calibration does not output a trouble too quickly, you have the option of a time delay and fine adjustment.

- Use Trigger delay to define the delay in seconds.
- Fine adjustment is possible under **Sensitivity**.

For the setting to take effect, click on the floppy disk icon in the left menu bar to save.

In the event of a detected trouble, the relay output is triggered and indicated by a colored warning triangle.

The following trouble types can be detected by the various settings:

Trouble type	Prerequisite (setting activated)
Sensor fault, lens fault	Scene quality: Scene too bright and Scene too dark or Reference image check
IR illumination (hardware defect or IR camera setting)	Scene quality: Scene too dark

Trouble type	Prerequisite (setting activated)
Occluded	Reference image check
Defocussed or blurry image	
Tilted	
Too bright	Scene quality: Scene too bright
Too dark	Scene quality: Scene too dark

3.3 Video Management System

A Video Management System is a unique enterprise IP video security solution that provides seamless management of digital video, audio, and data across any IP network. It nevertheless offers interfaces and standards to integrate the camera. AVIOTEC 8000i IR is compatible with the Bosch video management system BVMS. A connection to other video management systems is possible, but must be checked in a single case.

4 Planning

A fire safety analysis should be performed to determine the characteristics of the area including a fire load calculation. The placement of the camera or cameras results from the application environment of the customer.

4.1 Application basics of video-based fire detection

4.1.1 Protection objective - Area monitoring

Here the focus is on monitoring an entire indoor and outdoor area. In most cases several cameras are necessary to monitor the area.

4.1.2 Protection objective - Area-Of-Interest

Only a certain area shall be monitored separately (e.g. a machine/dedicated storage area in a big storage area).

4.2 Flame/smoke sizes (50/75 cm)

These sizes are proposed because they are based on the fire sizes of standard test fires from EN 54 or ISO 7240 and thus offer comparability with standard fire detection technologies.

EN 54/ISO 7240 are only applicable for indoor areas. For outdoor areas see chapter Minimum distances.

4.3 Check list

It is recommended to determine the following parameters of the environment and include them in the planning.

1. What is required?

Floor plan available: Yes No

2. What should be monitored? (Inspection may be required)

Type of monitoring: Area monitoring Area-of-Interest

Detectable flame and smoke sizes:

Standard fire (50 cm flame/75 cm smoke) Other requirements: _____

3. Illumination situation

Available illumination: Natural light Artificial light Non-visible illumination (IR)

Illuminance levels: _____ lx At least 1 lx without IR Dynamics in the application

Potential backlight: Position, window facade, influence of the sun, see chapter Influencing factors at the installation site (outdoor) [Important, in order not to exceed the dynamic factor, do not align the camera position against windows or direct sunlight.]

Influencing factor	Countermeasure	Information
ILLUMINATION	Take care of a well illuminated environment. Use a luxmeter to determine the illumination values (see Illumination).	A well and evenly illuminated environment is important to achieve better image quality and therefore a better base for analyzing the video image.
DYNAMIC RANGE	The dynamic range in the detection area must be equal or less than factor 1000. Use a luxmeter to determine the illumination values. These values have to be collected successively in the same scene.	The dynamic range represents the ratio between the minimum and maximum brightness in the environment.
BACKLIGHT	Avoid backlights in the video image by: <ul style="list-style-type: none"> - Changing the camera position and monitor in another direction. - Changing the horizontal and/or vertical tilt angle. - Excluding windows and roof lights from the field of view of the camera. 	Backlights create bright areas in the video image and can lead to false alarms. Due to the high dynamic range resulting from the backlight, fires may not be detected.

Influencing factor	Countermeasure	Information
CONVEYOR BELTS	Use smoke masks in case conveyor belts cause false alarms.	Conveyor belts moving in another direction than downwards in the picture area might be identified as smoke.

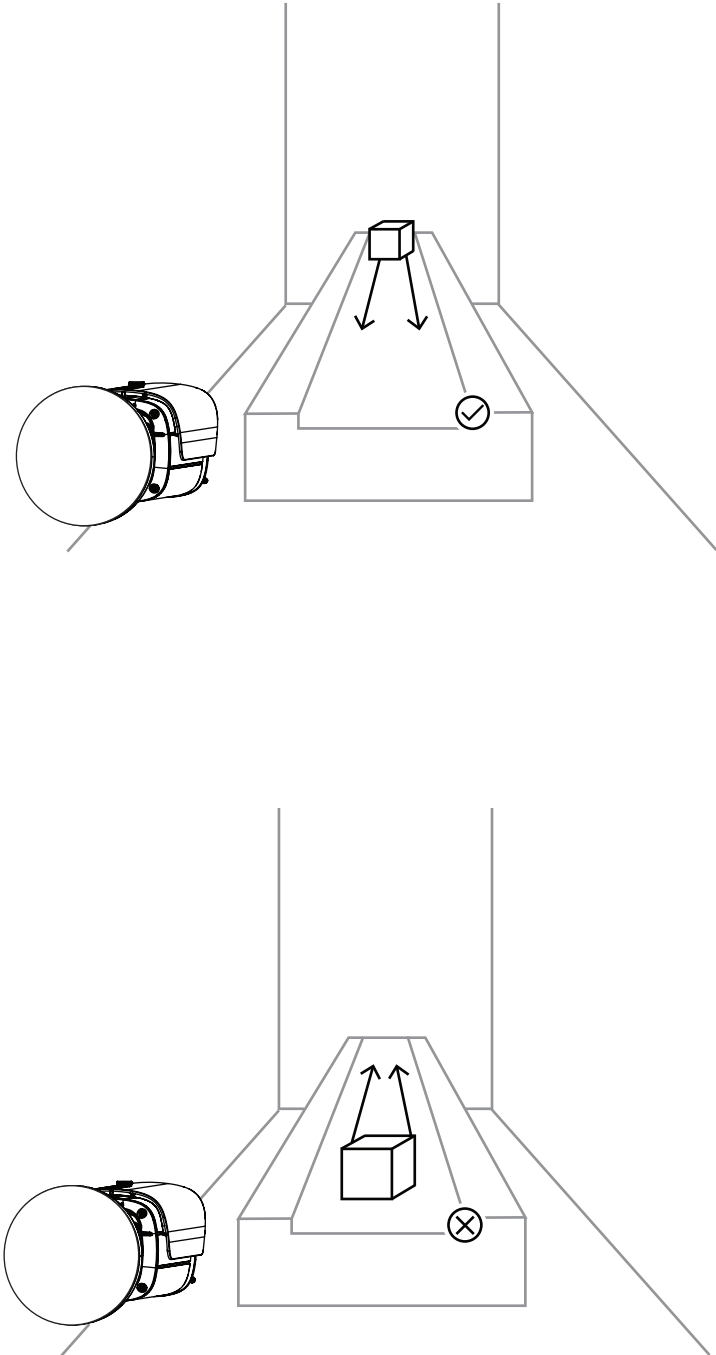
Influencing factor	Countermeasure	Information
 <p>The image contains two diagrams illustrating countermeasures for an influencing factor. Both diagrams show a camera on the left and a cube on a platform in the center. In the top diagram, two arrows point from the cube towards the camera, and a checkmark is in the bottom right corner. In the bottom diagram, the cube is on the platform and two arrows point away from the camera, with an 'X' in the bottom right corner.</p>		

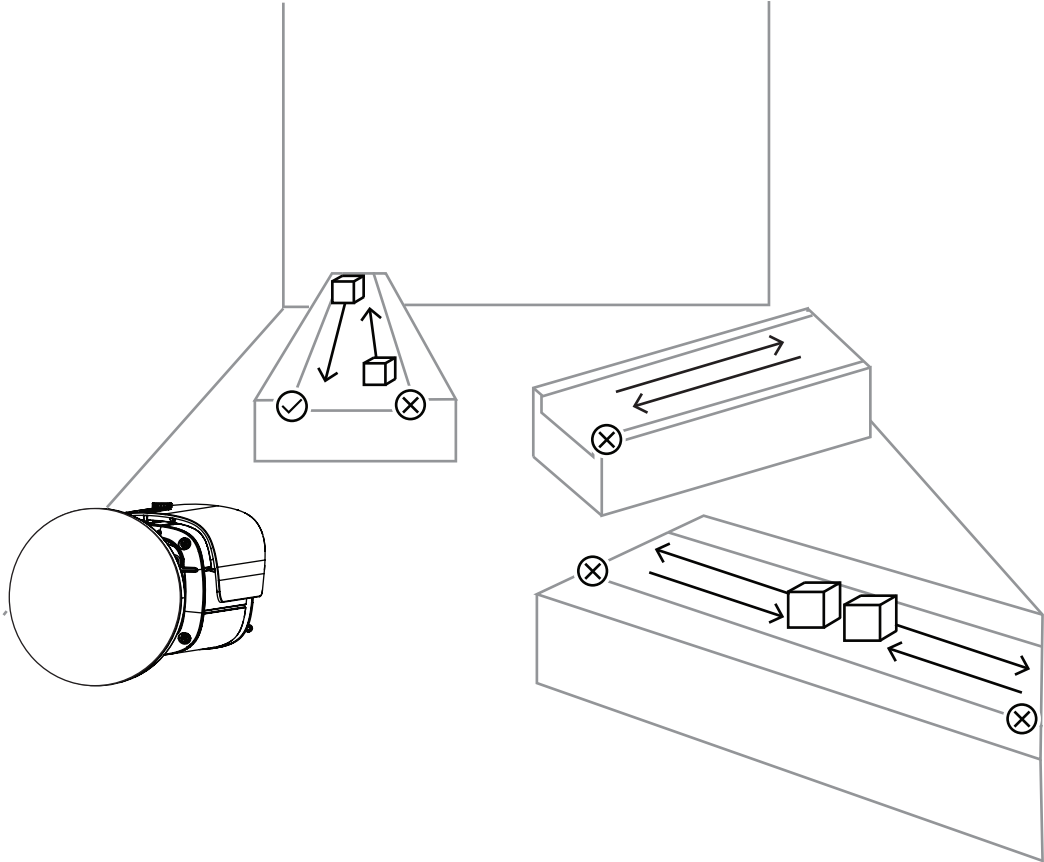
Influencing factor	Countermeasure	Information
		
<p>FANS</p>	<p>Avoid rotating fans in the field of view of the camera. Alternatively use masking (see Adjustments of image regions) in the configuration menu of the camera. If rotating fans can't be avoided in the scene, set Sensitivity to low to suppress false alarms (see General settings).</p>	<p>The visible rotating fan of a ventilation system may disturb the algorithm and could result in false alarms.</p>

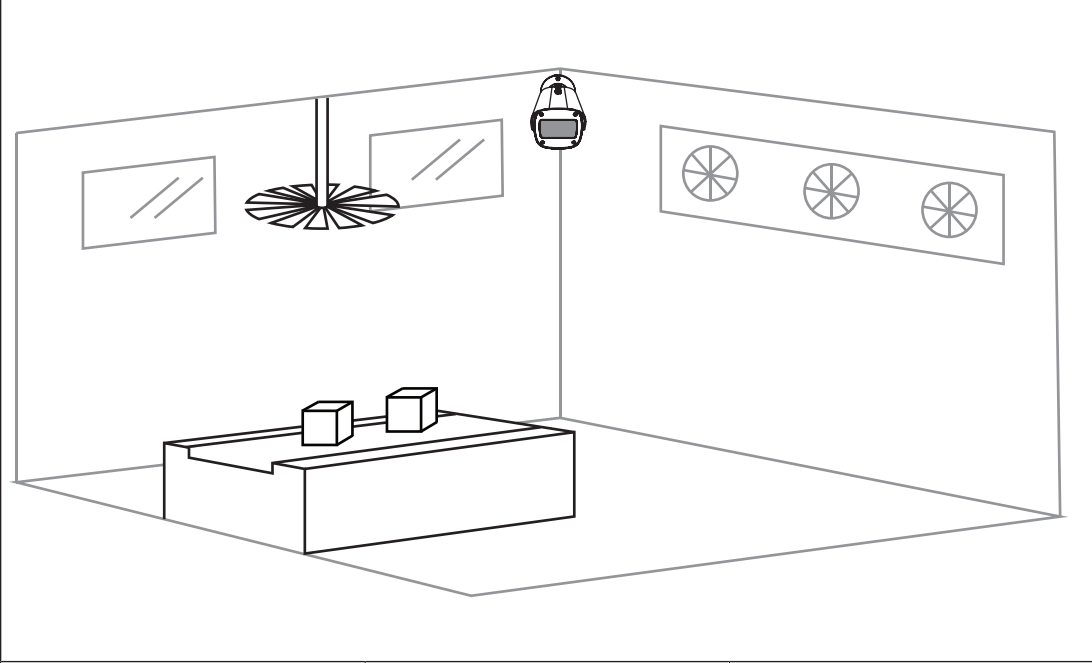
Influencing factor	Countermeasure	Information
		
<p>BLINKING LIGHTS</p>	<p>Check for blinking lights in your application. Use masking to exclude blinking lights from the detection or increase the verification time (see Adjustments of image regions). If blinking lights cause false alarms, set Sensitivity to low (see chapter General settings).</p>	<p>Blinking lights in the detection area may disturb the algorithm and lead to false alarms.</p>

Influencing factor	Countermeasure	Information
<p>LARGE / SLOW MOVING OBJECTS (e.g. cranes, large vehicles)</p>	<p>Avoid permanently installed and slow moving objects in the field of view of the camera.</p> <p>If large / slow moving objects are moving continuously in the same direction, mount the camera with view against the motion direction of the objects (like conveyor belts).</p> <p>In case of false alarms, set Sensitivity to low (see chapter General settings).</p>	<p>Large, slow moving objects behind other objects may have an appearance similar to fire or smoke and lead to false alarms.</p>
<p>VIBRATIONS</p>	<p>Only mount the camera in vibration isolated areas.</p>	<p>Vibrations can move and shake the camera and result in false alarms.</p>

4.5 Influencing factors at the installation site (outdoor)

Influencing factor	Countermeasure	Information
<p>WIND</p>	<p>Use larger opening angles.</p>	<p>With larger opening angles the smoke appears slower in the image.</p>

Influencing factor	Countermeasure	Information
		Notice: Changing the opening angle has an influence on smoke size and minimum distance. Refer to Minimum distances.
	Plan with larger flame sizes.	Flames might be pushed downwards by wind and appear smaller in the camera picture. Larger flames must be considered in the planning.
	2 nd camera positioned from a different viewing angle.	Wind can move smoke towards the camera. This leads to a downward movement of smoke in the image. Smoke is not detected (downwards rising smoke is not detected by the algorithm).
	-	Rotating/turning smoke: <ul style="list-style-type: none"> - No constant moving direction - No detection possibility if there is no constant direction during the whole verification time
ILLUMINATION	Position and align the camera depending on the course of the sun. Use shadow areas.	Notice: If the background is too bright, flames might not be detected. Sun illuminated background may have the same color as flame color. Flames cannot be visible in front of such a background (see chapter Illumination and brightness).
SKY / CLOUDS in the field of view	Positioning the camera preferably high: <ul style="list-style-type: none"> - Tilt camera more towards the ground. - No sky in the field of view. 	Clouds: <ul style="list-style-type: none"> - May have similar behavior like smoke. - May trigger false alarms. Sky: <ul style="list-style-type: none"> - Very bright, backlight, dynamic factor in field of view - Possibility of non-detections

4.6 Minimum distances

4.6.1 Indoor

The camera must be mounted according to the following graphic:

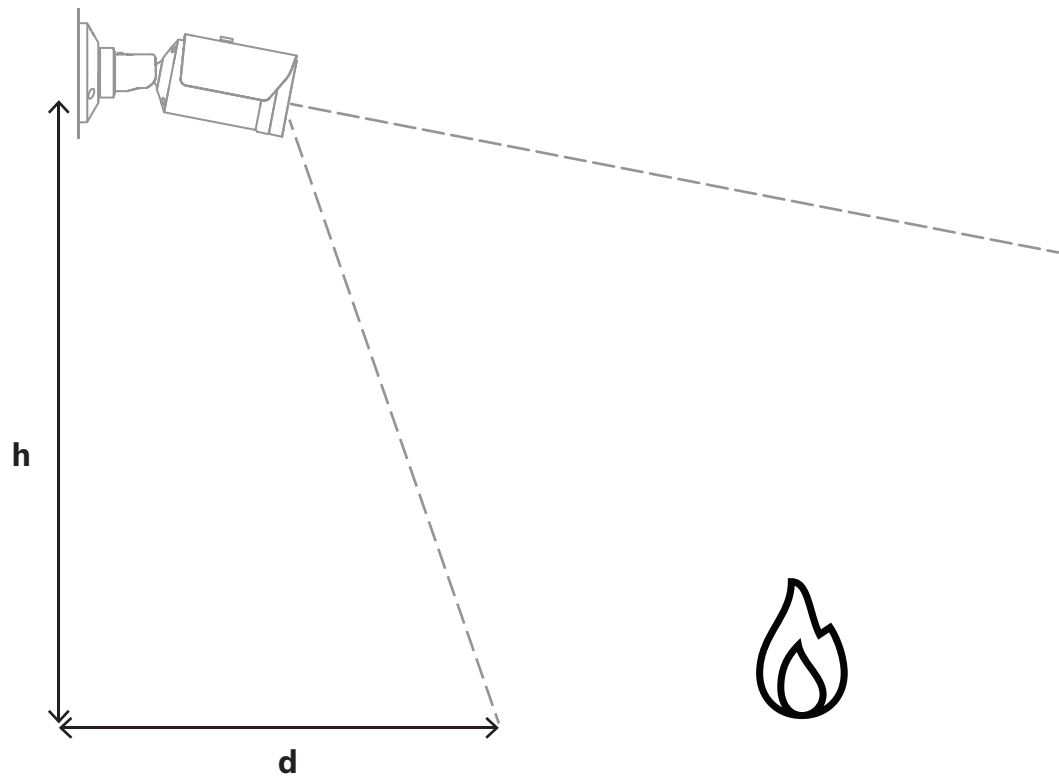

d	Minimum distance to fire
h	Installation height

The table below demonstrate exemplarily the minimum distances to fire or smoke depending on the installation height:

Indoor

Installation height [m]	Minimum distance to fire [m]
2.5	2.98
3	3.58
3.5	4.17
4	4.77
4.5	5.36
5	5.96
5.5	6.56
6	7.15
6.5	7.75
7	8.34

7.5	8.94
8	9.54
8.5	10.13
9	10.73
9.5	11.32
10	11.92

4.6.2

Outdoor

Outdoor

Wind speed m/s	Minimum distance [m]		
	100°	60°	45°
1	1.39	2.88	4.02
7	9.78	20.20	28.16
19	26.57	54.84	76.45
33	46.15	95.26	132.78

Minimum distance to fire (m) depending on different wind speeds

The following tables provide information about the minimum distances to fire (m) depending on different wind speeds.

The calculated distances refer to the same wind speeds in all tables. Since the minimum detection values are related to this, the following detection values apply to the distance specifications given below:

Wind speed			Detection Sizes [m]	
m/s	km/h	Beaufort	Flame	Smoke
1	4	1	0.11	0.16
7	25	4	0.82	1.19
19	69	8	2.32	3.37
33	119	12	4.03	5.87



Notice!

The minimum detection distance also depends on installation height (see chapter Minimum distances), tilt angle of the camera and opening angle of the lens.

4.7

Maximum distances

4.7.1

Indoor

The tables below demonstrate exemplarily the maximum distances to a fire depending on fire size and opening angle of the camera lens:

Maximum distance to fire in m (Flame detection)

Opening angle [°]			
	100	60	45
Fire width [m]			
0.3	18.2	27.6	36
0.5	30.4	46.1	60
1	60.9	92.2	120
2	121.9	184.4	240.1

Maximum distance to fire in m (Smoke detection)

Opening angle [°]			
	100	60	45
Smoke width [m]			
0.3	12.5	19.3	25.2
0.5	21.3	32.2	42
1	42.6	64.5	84
2	85.3	129	168.1

Maximum distances

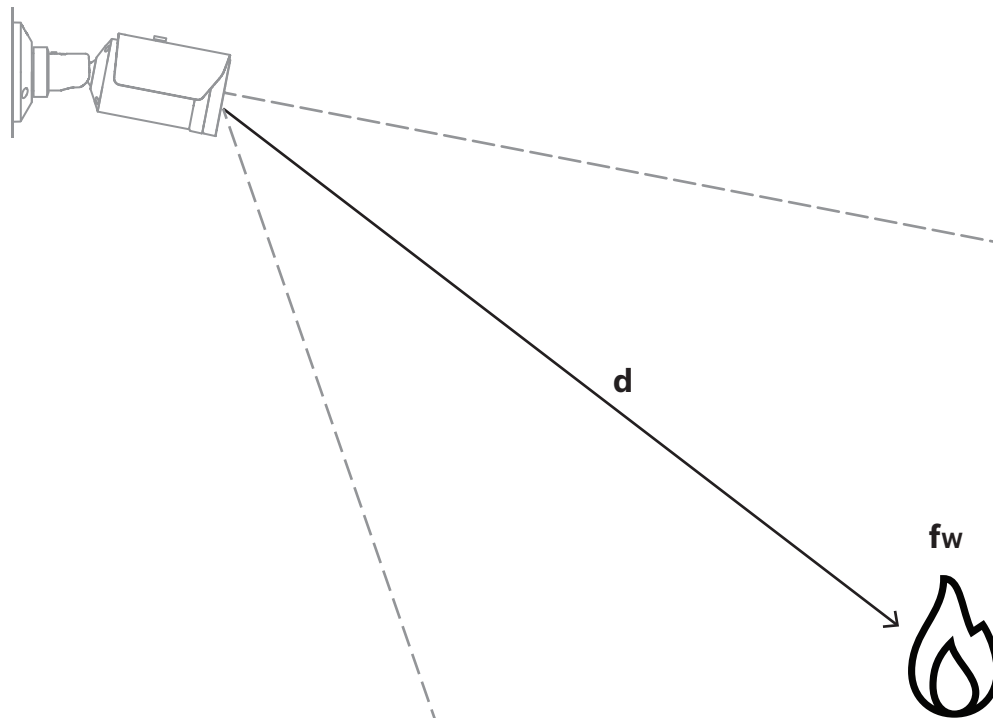

d	Maximum distance to fire
f _w	Fire width

4.7.2

Outdoor

The maximum distance is either given by the customer defined maximum flame and smoke size or by the minimum smoke speed (see Minimum distances).

4.8



Immediate environment of the camera

4.8.1

Illumination and brightness

Backlight should be avoided. The visibility of a smoke plume or flames decreases rapidly with increasing backlight. Try to minimize the amount of very bright background lights in your specific environment as far as it is meaningful and possible.



Flame and backlight	Flame without backlight
<p>AVIOTEC 8000i IR needs a minimum illumination of 1 lx. Generally, a uniformly illuminated monitoring area with a dynamic range in the camera image equal or less than factor 1000 is advantageous.</p>	
	
Smoke plume and backlight	Smoke plume without backlight

4.8.2 Infrared (IR) illumination



Notice!

When using infrared light, it is necessary to set the **Day/Night** mode in the camera menu to **Monochrome** or **Auto**.



Notice!

If you use infrared light in poor lighting situations and different lighting situations arise in your application, the fire detection must be tested again in each lightning situation!

Generally, a uniformly infrared illuminated monitoring area with a dynamic range in the camera image equal or less than factor 1000 is advantageous.



Infrared backlight is to be avoided. The visibility of a smoke plume or flames decreases rapidly with increasing Infrared backlight. Try to minimize the amount of very bright background lights in your specific environment as far as it is meaningful and possible.



4.8.3 Privacy protection

To protect privacy, individual masks on the video screen can be defined to cover up areas in which privacy has to be guaranteed. Privacy defined masks remain stored after a reset of the camera, even after upgrading to a new firmware.

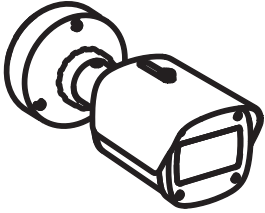
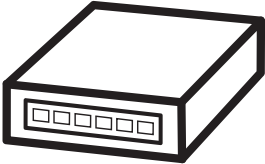
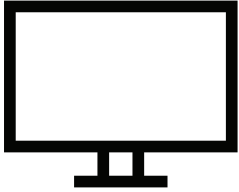
5 Camera integration

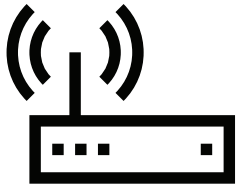
The video-based fire detection can be easily integrated into the network environment of the customer. There are several possibilities to connect the camera. Various combinations are possible. The individual customer network properties determine the performance and scalability of the system.

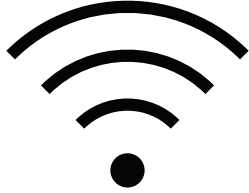
	<p>Camera</p>
	<p>Network switch, PoE-ready</p>
	<p>Client PC</p>
	<p>Video Recording Manager (VRM)</p>
	<p>Router</p>

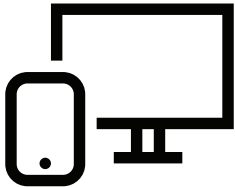
	Internet
	Monitoring Center
	Fire alarm control panel
	Mobile devices

5.1 Local Area Network

Due to the IP-based camera, the integration of the video-based fire detection into the network of the customer is easy. There are a lot of opportunities regarding to scalability and enlargement of the network.

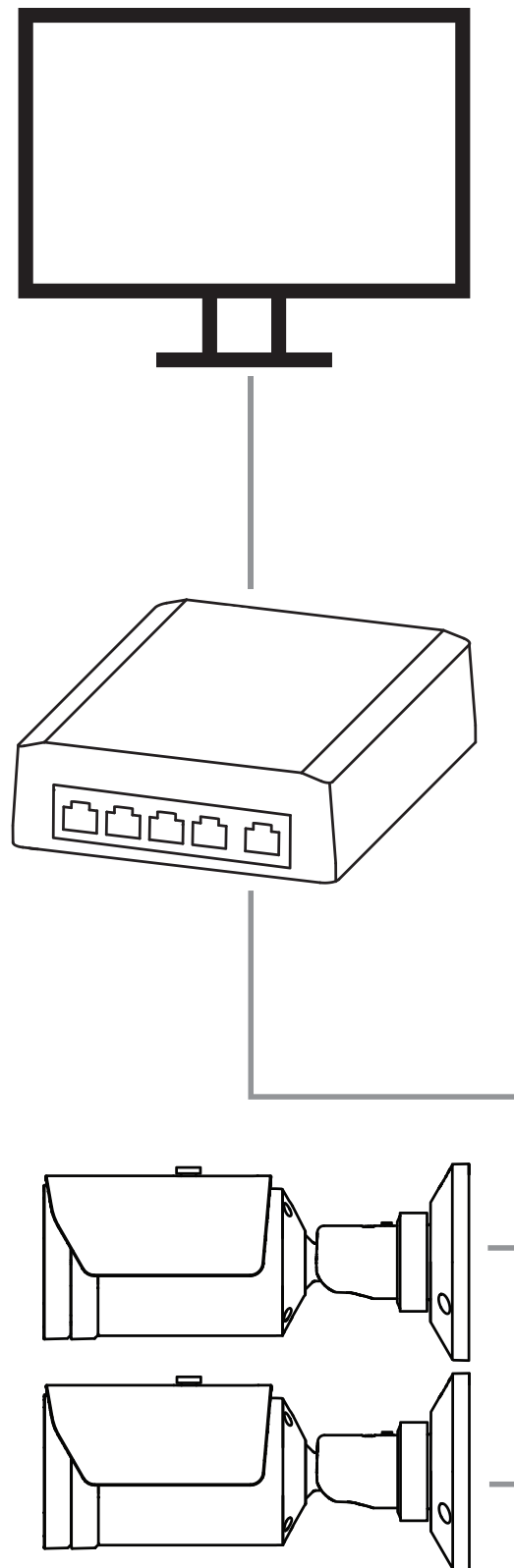

5.2

Local Area Network with recording solution

Recording and archiving functionality in the network can be realized by a video recording manager (VRM). Fire cause analysis and traceability due to legal matters are only two examples of a recording solution.

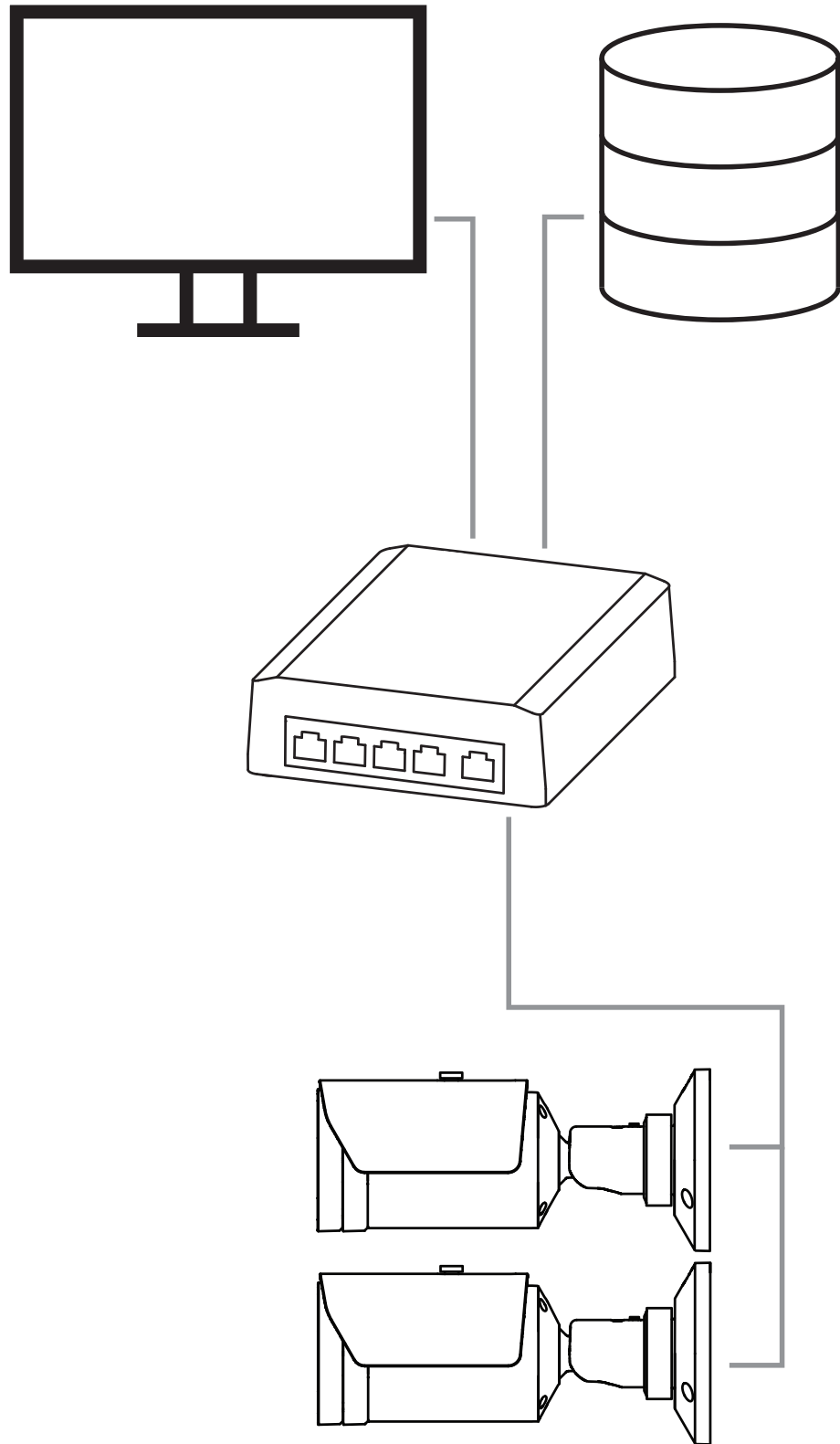

5.3 Monitoring Center

In a monitoring center, alarms can be verified to call the fire brigade and to take care of additional rescue measures.

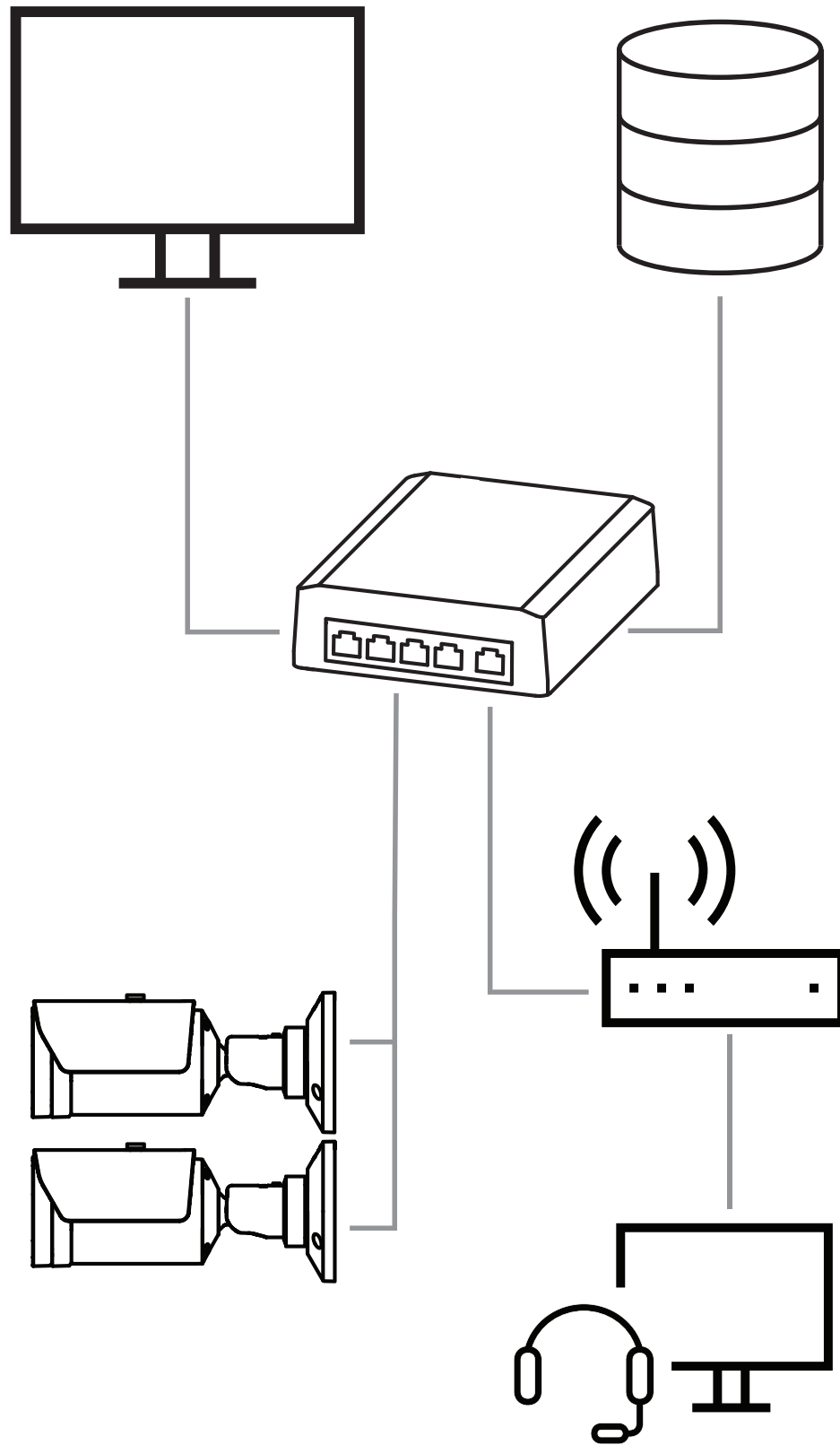

5.4 Fire Alarm Control Panel

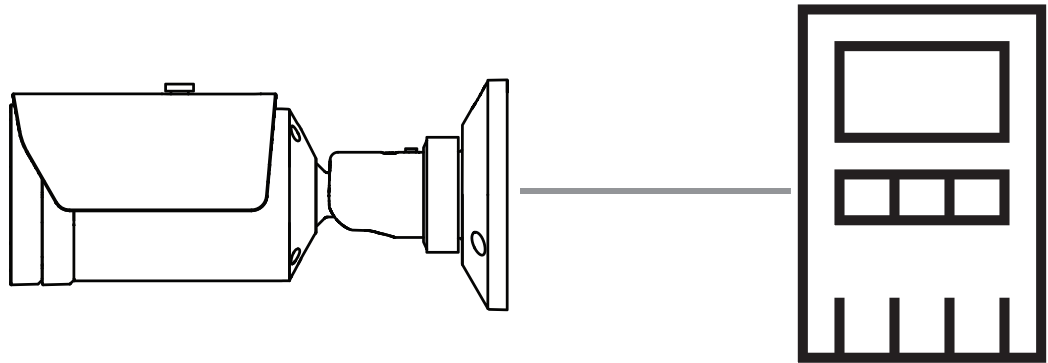

AVIOTEC 8000i IR can be connected to the a fire alarm control panel. Alarms and troubles will be triggered by relay outputs of the camera. There are two separate relays for alarm and trouble.



Notice!

No direct connection to fire services in EN54 compliant installations. Authorities can allow a connection to fire services after verifying alarms in a monitoring center. Please consider local regulations.

Connection to a fire alarm control panel

The alarm output of the camera can be connected to a fire alarm control panel.

The camera alarm output is triggered by a relay that is normally open. In case of alarm the relay is closed.

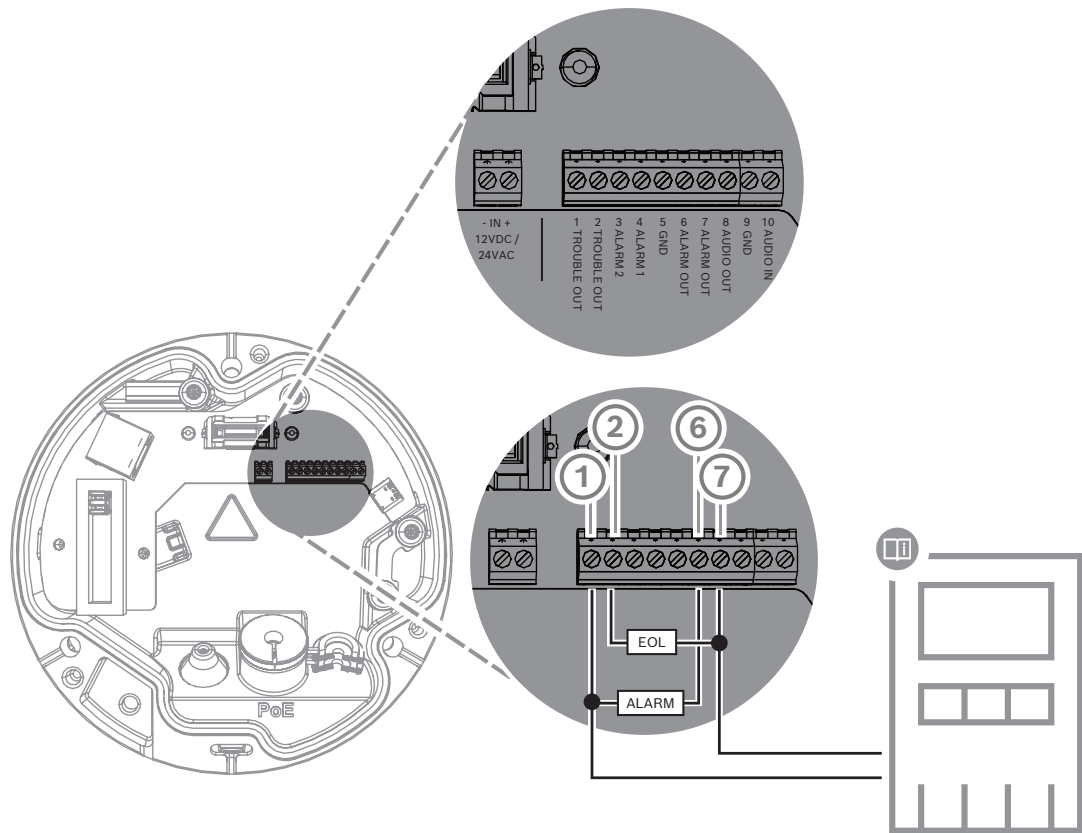

See the documentation of the individual manufacturer for further information about the connection to a fire alarm control panel.

5.5 Mobile Devices

Another advantage of the network integration of the video-based fire detection is the expandability to mobile devices, such as tablets or smartphones.

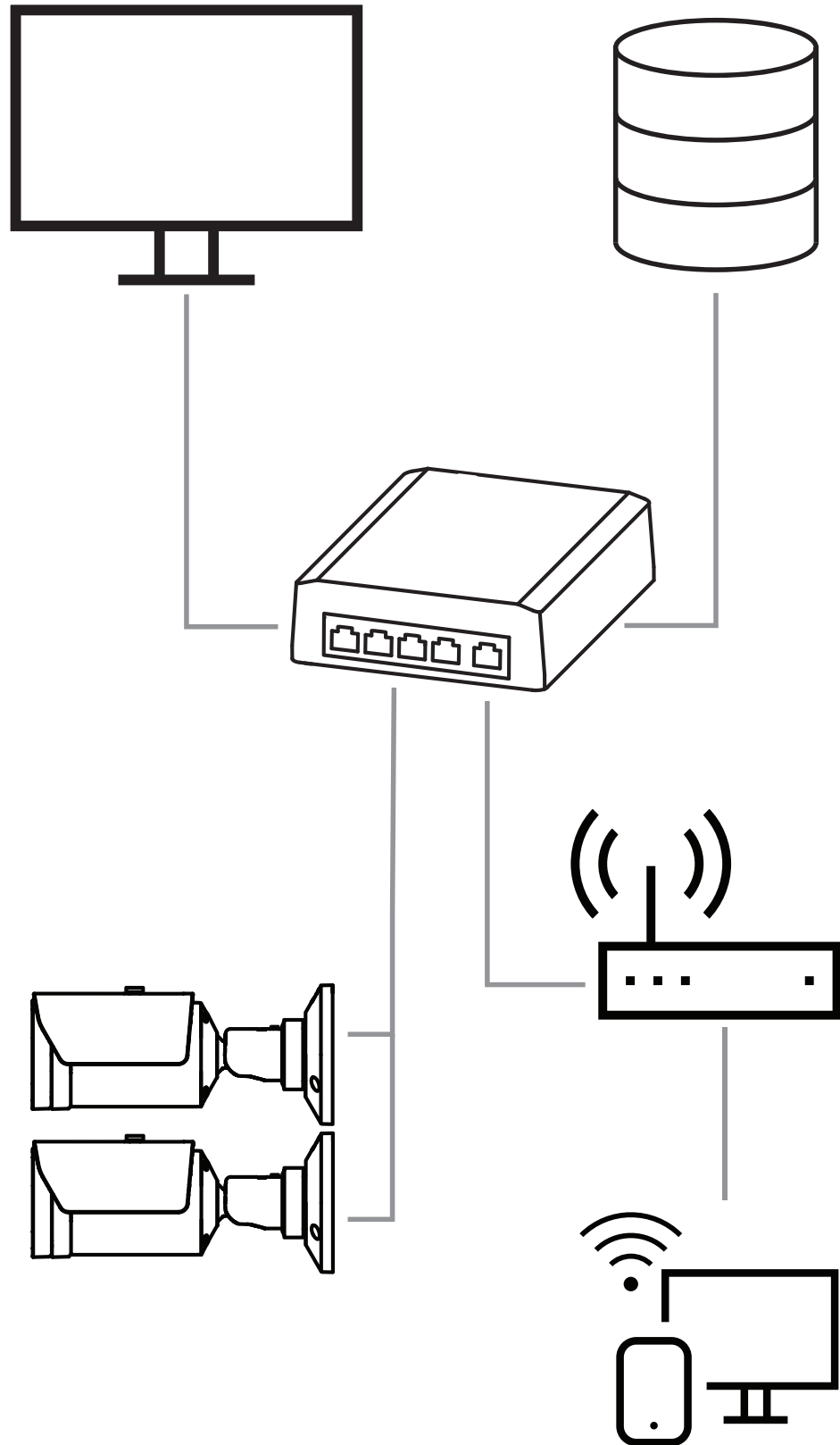

6 Use cases

Video content analysis (VCA) is the process of automatically analyzing video images to alarm on predefined events like the detection of moving objects. Fire profiles base on VCA. There are four use cases with the aid of different profiles. These four use cases are described below.

6.1 Fire detection only

This is the standard setting of the camera. You can choose this standard option if different fire detection profiles and profile scheduling are not necessary for your application. In case you need to adapt the general fire detection settings, please refer to chapter Adjustment of detection settings.

6.2 Fire detection profiles

If you want to use **Tamper detection** additionally for fire detection, you can choose Fire #1 or Fire #2.

The profiles can be renamed in the Configuration Manager.

6.3 Scheduled fire detection



Notice!

Configuration only available in Configuration Manager.

In many industrial applications you have a lot of movement during the day and very little movement at night. A scheduled configuration allows you to link a VCA profile with the days and times at which the video content analysis is to be active. Schedules can be defined for weekdays and for holidays.

Define holidays on which a profile should be active that are different to the standard weekly schedule.

1. Click the **Holidays** tab. Any days that have already been selected are shown in the table.
2. Assign the individual holidays to the desired VCA profiles.
3. For the setting to take effect, click on the floppy disk icon in the left menu bar to save.

Define weekdays on which a profile should be active that are different to the standard weekly schedule.

1. Click the **Weekdays** tab. Any days that have already been selected are shown in the table.
2. Assign the individual weekdays to the desired VCA profiles.
3. For the setting to take effect, click on the floppy disk icon in the left menu bar to save.

6.4 External trigger to switch fire detection mode

One example would be an environment with cleaning cycles. A key switch can be used as an external trigger to switch between the different fire detection profiles.

The camera offers two alarm inputs. Configure the input behavior in the Configuration Manager under **VCA** > Main Operation > **Event triggered**.

7 Technical data

Algorithm Overview	
Min. detection size for Smoke, standard setting (% of picture width)	1.6
Smoke speed (% of picture height/s)	0.5 - 16
Smoke speed (% of picture width/s)	0%-30%
Min. Smoke density (%)	needs to be visible in the picture
Min. detection size for Flame, standard setting (% of picture width)	1.1
Min. illumination level (lx)	1
Min. illumination level with IR illumination (lx)	0
Max. illumination level for flame detection (lx)	20,000

8 Troubleshooting

The following issues can be solved in the detection settings in the Configuration Manager or in the web browser menu (**Configuration > Alarm > Fire detection**).

8.1 False Alarms

8.1.1 False alarms under 4 seconds concerning the whole detection area

In this case the general settings of the fire detection have to be adjusted.

Problem	Solution
Short false alarms for smoke detection.	Increase the duration of smoke detection. (Smoke > Verification time [s])
Short false alarms for flame detection.	Increase the duration of flame detection. (Flames > Verification time [s])

8.1.2 False alarms at small constant areas

Individual image areas are affected and have to be adjusted.

Problem	Solution
Objects cause flickering motion, e.g. shadow of a flag in the wind.	Mask out the disturbing image area (for flame). <i>Flame detection will be deactivated in this mask.</i>
Continuous motion in the picture causes false alarms, e.g. escalators.	Mask out the disturbing image area (for smoke). <i>Smoke detection will be deactivated in this mask.</i>
Temporary motion causes false alarms, e.g. roller shutter.	Mask out the disturbing image area (smoke time mask). <i>Smoke detection will be delayed in this mask.</i>

8.1.3 Vibrations at the camera site

Problem	Solution
Vibrations are transferred to the camera.	Avoid vibrations at the camera site.
Camera picture is trembling.	Make sure the camera is firmly mounted.
The camera position changed because of vibrations.	Move the camera to its initial position and check the field of view. Make sure the camera is firmly mounted.

8.2 No alarm transmission

Problem: Alarms are visible in the web browser but there is no alarm transmission to the video client.

Solution:

- Check network connection and settings (**Configuration > Network**)
- Check relay connection and settings (**Alarm > Alarm Outputs**)
- Check fire detection settings (**Configuration > Alarm > Fire detection**)

- Check the video client settings

8.3 No fire detection

- **Problem:** No detection of fire.
- **Solution:**
- Check fire detection settings (**Configuration > Alarm > Fire detection**)
- Check mask settings
- Check privacy mask settings
- Check the focus of the lens (**Configuration > Camera -> Installer Menu > Open...**)
- Check obstructions in the field of view
- Check the detection area
- Check minimum/maximum distance to fire
- Check the illumination. Different lighting conditions (e.g. sodium light) might require the use of the Expert Mode.

8.4 Image quality

Interference of the camera image

Small image areas or the whole image area are affected by interferences.

Problem	Solution
Artificial light, e.g. fluorescent light, causes flickering of the camera image.	Go to Configuration > Camera > Installer Menu > ALC mode and change to fluorescent mode.

8.5 Camera

If a fault cannot be resolved, please contact your supplier or system integrator, or go directly to Customer Service.

The version numbers of the internal firmware can be viewed on a service page. Please note this information before contacting Customer Service.

1. In the address bar of your browser, after the unit IP address, enter: /version
for example: 192.168.0.80/version
2. Write down the information or print out the page.

The camera offers a variety of configuration options. Therefore, check that it works properly after installation and configuration. This is the only way to ensure that the camera will function as intended in the event of an alarm.

Your check should include the following functions:

- Can you connect to the camera remotely
- Does the camera transmit all the data required?
- Does the camera respond as desired to alarm events?
- Is it possible to control peripheral devices, if necessary?

The camera has one LED on the rear panel: It indicates the status of the camera status (red for error; green for OK).

No OSD messages appear.	Special Video SDK is required. Video management software from third parties does not use the SDK.
-------------------------	---

The ping command can be used to check the connection between two IP addresses. This allows testing whether a device is active in the network.

1. Open the command prompt.

2. Type `ping` followed by the IP address of the device.

If the device is found, the response appears as "Reply from ... ", followed by the number of bytes sent and the transmission time in milliseconds. Otherwise, the device cannot be accessed via the network. This might be because:

- The device is not properly connected to the network. Check the cable connections in this case.
- The device is not correctly integrated into the network. Check the IP address, subnet mask, and gateway address.

9 Appendices

Maximum detection distances for margin areas

Due to the optical distortion of the lens, there are deviating maximum detection distances at the margin area of the picture.

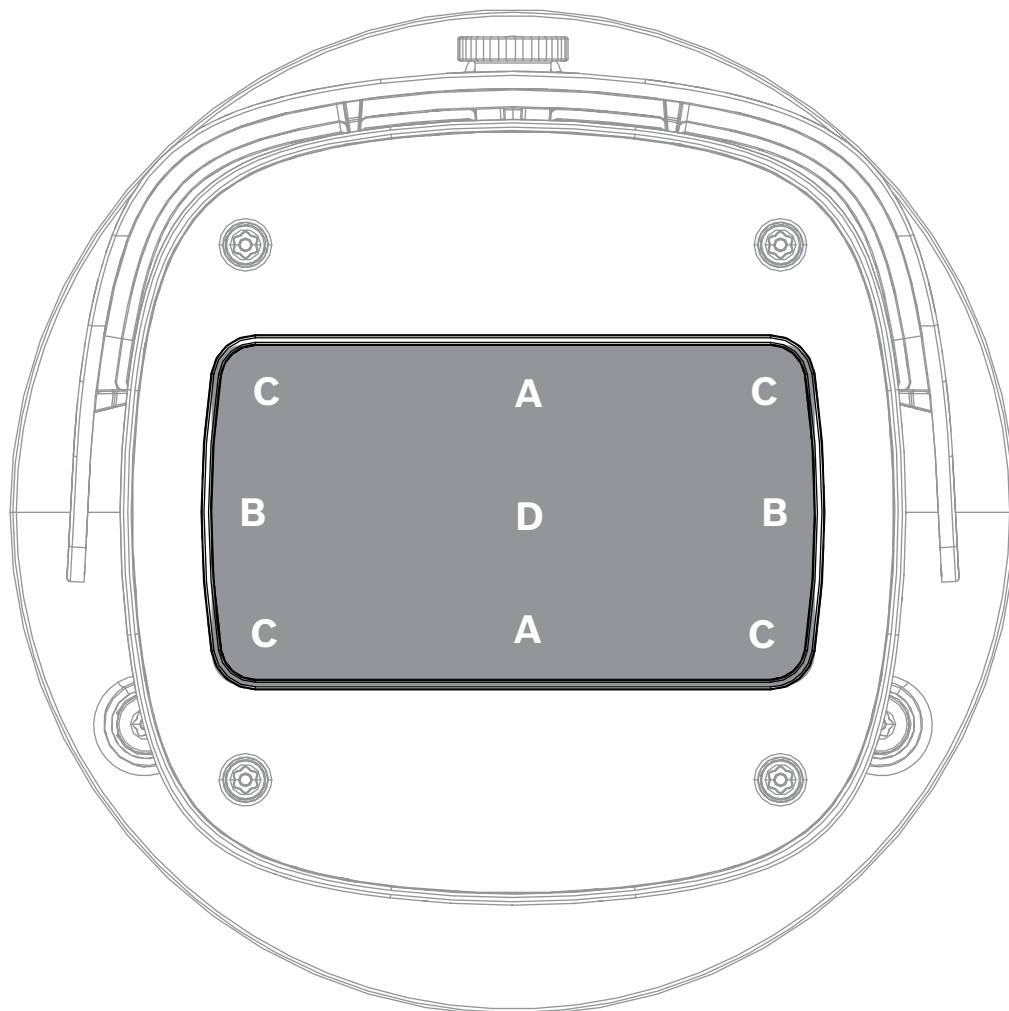

Figure 9.1: Definition of margin areas of the picture

A	Horizontal margin area
B	Vertical margin area
C	Corner area
D	Center

9.1 Flame detection

Opening angle 48.5°

Flame width (m)	A	B	C	D
0.3	29.6	23.4	22.9	30.4

0.5	49.4	39.1	38.2	50.7
0.75	74.2	58.8	57.4	76.1
1	98.9	78.3	76.5	101.4
1.25	123.6	97.9	95.7	126.8
1.5	148.4	117.6	114.9	152.2

Opening angle 60°

Flame width (m)	A	B	C	D
0.3	22.8	15.5	15	23.7
0.5	38	25.9	25.1	39.5
0.75	57.1	38.9	37.7	59.3
1	76.2	51.9	50.3	79.1
1.25	95.3	64.9	62.9	98.9
1.5	114.4	77.9	75.6	118.7

Opening angle 75°

Flame width (m)	A	B	C	D
0.3	16.9	9.1	9	17.8
0.5	28.2	15.2	15.1	29.7
0.75	42.4	22.9	22.7	44.6
1	56.6	30.6	30.3	59.5
1.25	70.8	38.3	37.9	74.4
1.5	85	45.9	45.4	89.3

Opening angle 90°

Flame width (m)	A	B	C	D
0.3	12.8	5.1	5.2	13.7
0.5	21.4	8.5	8.7	22.8
0.75	32.1	12.7	13	34.2
1	43	17	17.4	45.7
1.25	53.7	21.2	21.8	57.1
1.5	64.4	25.5	26.1	68.5

Opening angle 100°

Flame width (m)	A	B	C	D
0.3	10.9	3.3	3.5	11.5
0.5	18.2	5.5	5.9	19.1

0.75	27.4	8.3	8.9	28.7
1	36.5	11.1	11.9	38.3
1.25	45.7	13.8	14.9	47.9
1.5	54.9	16.6	17.9	57.5

9.2 Smoke detection

Opening angle 48.5°

Smoke width (m)	A	B	C	D
0.3	20.7	16.4	16	21.3
0.5	34.6	27.4	26.8	35.5
0.75	51.8	41.1	40.1	53.2
1	69.2	54.8	53.6	71
1.25	86.5	68.5	66.9	88.7
1.5	103.8	82.2	80.4	106.5

Opening angle 60°

Smoke width (m)	A	B	C	D
0.3	16	10.9	10.5	16.6
0.5	26.7	18.1	17.6	27.7
0.75	40	27.2	26.4	41.5
1	53.4	36.3	35.2	55.4
1.25	66.7	45.4	44	69.2
1.5	80.1	54.5	52.9	83.1

Opening angle 75°

Smoke width (m)	A	B	C	D
0.3	11.9	6.4	6.3	12.5
0.5	19.8	10.7	10.5	20.8
0.75	29.7	16	15.8	31.2
1	39.7	21.4	21.2	41.7
1.25	49.6	26.8	26.5	52.1
1.5	59.5	32.1	31.8	62.5

Opening angle 90°

Smoke width (m)	A	B	C	D
0.3	9	3.5	3.6	9.6
0.5	15	5.9	6.1	16
0.75	22.5	8.9	9.1	24
1	30.1	11.9	12.2	32
1.25	37.6	14.9	15.2	40
1.5	45.1	17.9	18.3	48

Opening angle 100°

Smoke width (m)	A	B	C	D
0.3	7.6	2.3	2.5	8
0.5	12.7	3.8	4.1	13.4
0.75	19.1	5.8	6.2	20.1
1	25.5	7.7	8.3	26.8
1.25	31.9	9.7	10.4	33.5
1.5	38.3	11.6	12.5	40.2

Bosch Sicherheitssysteme GmbH

Robert-Bosch-Ring 5

85630 Grasbrunn

Germany

© Bosch Sicherheitssysteme GmbH, 2023

Building solutions for a better life.

202310121759