

# DINION IP ultra 8000 MP

www.boschsecurity.com



**BOSCH**  
Invented for life



- ▶ 12MP (4K UHD) for exceptional detail at fast speeds
- ▶ Built-in Intelligent Video Analytics to trigger relevant alerts and quickly retrieve data
- ▶ Low network strain and storage costs
- ▶ Outstanding wide dynamic range (92+16 dB)
- ▶ Long distance identification with telephoto lenses

The DINION IP ultra 8000 MP with 12 megapixel resolution offers crisp, clear and extremely detailed images for the most demanding IP video surveillance requirements. It captures 12 megapixel at 20 fps, and 4K UHD at 30 fps, so providing images of fast moving objects in high resolutions. The content-rich image allows effective retrospective analysis at the level of detail that makes the difference when collecting forensic evidence.

The camera offers a wide-angle overview and multiple focus points on a single screen so now you can focus on details without losing the bigger picture.

## Versions

The camera is available in the following versions:

- Camera body with permanently attached 5 mm lens.
- Camera body with permanently attached 3.2 mm lens.
- Camera body with C/CS lens mount and motorized focus adjustment.

Three telephoto lenses (75 mm, 50 mm and 35 mm), specifically matched to the camera body, are optionally available.

## System overview

Advanced image processing techniques take the DINION IP ultra 8000 MP to the next level. Intelligent Video Analysis tracks and focuses on relevant situations and adds sense and structure to stored video, allowing you to quickly retrieve the correct data. Intelligent Auto Exposure gives superb front and back light compensation, providing you with the perfect picture every time.

Intelligent Dynamic Noise Reduction saves bitrate at the source and only uses bandwidth when needed. This results in up to 50% less bitrate and significantly reduces storage costs and network strain without compromising on video quality.

## Functions

### Measured dynamic range

The dynamic range of the camera is outstanding and is obvious in real world performance comparisons – 92 dB wide dynamic range for 4K UHD mode (plus an extra 16 dB when combined with Intelligent Auto Exposure).

The actual dynamic range of the camera is measured using Opto-Electronic Conversion Function (OECF) analysis with a standardized test chart based on ISO

standards. This method provides more realistic and verifiable results in comparison with the theoretical approximations sometimes used.

### Intelligent Video Analysis

After only 20 minutes you can miss 90% of the activity on a screen. Intelligent Video Analysis (IVA ) assists by alerting you when predefined alarms are triggered. By smartly combining up to 8 IVA rules, complex tasks are made easy and false alarms are reduced to a minimum. IVA also adds sense and structure to your video by adding metadata. This enables you to quickly retrieve the relevant images from hours of stored video. Metadata can also be used to deliver irrefutable forensic evidence or to optimize business processes based on people counting or crowd density information.

### Intelligent Auto Exposure

Fluctuations in backlight and front light can ruin your images. To achieve the perfect picture in every situation, Intelligent Auto Exposure automatically adjusts the exposure of the camera. It offers superb front light compensation and incredible backlight compensation by automatically adapting to changing light conditions.

### Intelligent Dynamic Noise Reduction

Quiet scenes with little or no movement require a lower bitrate. By intelligently distinguishing between noise and relevant information, Intelligent Dynamic Noise Reduction reduces bitrate by up to 50%. Because noise is reduced at the source during image capture, the lower bitrate does not compromise on video quality.

With the release of FW6.40 an extra level of intelligence is added with Intelligent Streaming. The camera provides the most usable image possible by cleverly optimizing the detail-to-bandwidth ratio. The smart encoder continuously scans the complete scene as well as regions of the scene and dynamically adjusts compression based on relevant information like movement. Together with Intelligent Dynamic Noise Reduction, which actively analyzes the contents of a scene and reduces noise artifacts accordingly, bitrates are reduced by up to 80%. Because noise is reduced at the source during image capture, the lower bitrate does not compromise image quality. This results in substantially lower storage costs and network strain and still retain a high image quality and smooth motion.

### Area-based encoding

Area-based encoding is another feature which reduces bandwidth. Compression parameters for up to eight user-definable regions can be set. This allows uninteresting regions to be highly compressed, leaving more bandwidth for important parts of the scene.

### Bitrate optimized profile

The average typical optimized bandwidth in kbits/s for various frame rates is shown in the table:

fps	12MP (4:3)	4K UHD	1080p
30	-	3000	800
25	-	2839	757
15	2712	2389	637
10	2306	2031	541
5	1612	1420	379
2	694	611	163

### Selectable resolution and aspect ratio

The camera has three basic application variants that can be chosen at start-up to provide the best possible performance for typical applications:

- 12MP (4:3)
- 4K UHD (16:9)
- 1080p (16:9)

The 12MP variant can be used in applications where the highest resolution possible is required. The 4K UHD variant is suitable for applications where the 16:9 4K standard is required with a frame rate of 30 fps. The 1080p30 (16:9) variant is for applications that require extra sensitivity and dynamic range. Each of these variants selects the best possible tuning parameters for the application so that you get the best performance possible from your camera.

### Scene modes

The camera has a very intuitive user interface that allows fast and easy configuration. Nine configurable modes are provided with the best settings for a variety of applications. Different scene modes can be selected for day or night situations.

- **Indoor** – general day-to-night changes in an indoor environment without sun highlights or street lighting effects.
- **Outdoor** – general day-to-night changes in an outdoor environment with sun highlights and street lighting effects.
- **Night-optimized** – optimized for details in low light environments.
- **Low bit rate** – reduces bandwidth requirements.
- **Intelligent AE** – optimized for scenes with fluctuating front and back light caused by sunlight or other illuminated objects in the scene.
- **Vibrant** – enhanced contrast, sharpness and saturation.
- **Sports and gaming** – high-speed capture, and improved color rendition and sharpness.
- **Traffic** – for monitoring traffic movement on roads or parking lots. It can also be used in industrial applications where fast moving objects are to be monitored. Motion artifacts are minimized.
- **Retail** – improved color rendition and sharpness with reduced bandwidth requirements.

### Multiple streams

The innovative multi-streaming feature delivers various H.264 streams together with an M-JPEG stream. These streams facilitate bandwidth-efficient viewing and recording, plus easy integration with third-party video management systems.

Depending on the resolution and frame rate selected for the first stream, the second stream provides a copy of the first stream or a lower resolution stream.

#### Stream assignments

Application variant	Stream 1	Stream 2
12MP (4:3) @ 20 fps	4000 x 3000	Copy of stream 1
12MP (4:3) @ 15 fps	4000 x 3000	Copy of stream 1
		SD: 640 x 480
		SD ROI: 640 x 480
		upright cropped: 400 x 720
		SD dual ROI: 640 x 480
4K UHD (16:9) @ 25/30 fps	3840 x 2160	Copy of stream 1
		800 x 600
7.3MP (16:9) @ 25/30 fps	3584 x 2016	SD: 768 x 432
		SD ROI: 768 x 432
		upright cropped: 400 x 720
		D1 4:3 cropped: 704 x 480
		SD dual ROI: 768 x 432
4K UHD (16:9) @ 15 fps	3840 x 2160, 3584 x 2016	Copy of stream 1
		SD: 768 x 432
		720p: 1280 x 720
		1080p: 1920 x 1080
		SD ROI: 768 x 432
		upright cropped: 400 x 720
		D1 4:3 cropped: 704 x 480
SD dual ROI: 768 x 432		
1080 (16:9) @ 25/30 fps	1920 x 1080	SD: 768 x 432
		720p: 1280 x 720
		1080p: 1920 x 1080
		SD ROI: 768 x 432
		upright cropped: 400 x 720
		D1 4:3 cropped: 704 x 480

#### Stream assignments

1080 (16:9) @ 15 fps	1920 x 1080	SD dual ROI: 768 x 432
		Copy of stream 1
		SD: 768 x 432
		720p: 1280 x 720
		1080p: 1920 x 1080
		SD ROI: 768 x 432
		upright cropped: 400 x 720
		D1 4:3 cropped: 704 x 480
		SD dual ROI: 768 x 432

The third stream uses the I-frames of the first stream for recording; the fourth stream shows a JPEG image at a maximum of 10 Mbit/s.

### Regions of interest and E-PTZ

Regions of Interest (ROI) can be user defined. The remote E-PTZ (Electronic Pan, Tilt and Zoom) controls allow you to select specific areas of the parent image. These regions produce separate streams for remote viewing and recording. These streams, together with the main stream, allow the operator to separately monitor the most interesting part of a scene while still retaining situational awareness.

Intelligent Tracking continuously analyses the scene for moving objects. If a moving object is detected, the camera automatically adjusts its settings, including field of view, to optimally capture details of the object of interest.

### Easy installation

Power for the camera can be supplied via a Power-over-Ethernet compliant network cable connection. With this configuration, only a single cable connection is required to view, power, and control the camera. Using PoE makes installation easier and more cost-effective, as cameras do not require a local power source.

The camera can also be supplied with power from +12 VDC power supplies. To increase system reliability, the camera can be simultaneously connected to both PoE and +12 VDC supplies. Additionally, uninterruptible power supplies (UPS) can be used to ensure continuous operation, even during a power failure.

For trouble-free network cabling, the camera supports Auto-MDIX which allows the use of straight or cross-over cables.

### Storage management

Recording management can be controlled by the Bosch Video Recording Manager (Video Recording Manager) or the camera can use iSCSI targets directly without any recording software.

**Edge recording**

Insert a memory card into the card slot to store up to 2 TB of local alarm recording. Pre-alarm recording in RAM reduces recording bandwidth on the network, and extends the effective life of the memory card.

**Cloud-based services**

The camera supports time-based or alarm-based JPEG posting to four different accounts. These accounts can address FTP servers or cloud-based storage facilities (for example, Dropbox). Video clips or JPEG images can also be exported to these accounts.

Alarms can be set up to trigger an e-mail or SMS notification so you are always aware of abnormal events.

**Access security**

Password protection with three levels and 802.1x authentication is supported. To secure Web browser access, use HTTPS with a SSL certificate stored in the camera.

**Complete viewing software**

There are many ways to access the camera's features: using a web browser, with the Bosch Video Management System, with the free-of-charge Bosch Video Client, with the video security mobile app, or via third-party software.

**System integration**

The camera conforms to the ONVIF Profile S specifications. Compliance with these standards guarantees interoperability between network video products regardless of manufacturer.

Third-party integrators can easily access the internal feature set of the camera for integration into large projects. Visit the Bosch Integration Partner Program (IPP) website ([ipp.boschsecurity.com](http://ipp.boschsecurity.com)) for more information.

**Lens options**

The permanently attached wide-angled lenses of 5 mm or 3.2 mm are factory mounted and calibrated, and cannot be replaced in the field.

There are three telephoto lenses optionally available for the camera body version:

- a 35 mm lens (LFF-8012C-D35)
- a 50 mm lens (LFF-8012C-D50)
- a 75 mm lens (LFF-8012C-D75)

The separate camera body includes an auto-focus lens wizard to ensure that lenses can be easily focused.

The automatic motorized focus adjustment with 1:1 pixel mapping ensures that the camera with these telephoto lenses is always focused accurately.

**Housing options**

To protect the camera, two housings are optionally available (UHO-POE-10 and UHO-HBGS-x1). When choosing a housing keep the following in mind:

- A camera with a 75 mm telephoto lens is too long for the UHO-POE-10 housing; use the UHO-HBGS-x1 housing instead.

- A camera with a 3.2 mm factory-mounted lens has a restricted view at the edges in the UHO-HBGS-x1 housing; use the UHO-POE-10 housing instead.

**DORI coverage**

DORI (Detect, Observe, Recognize, Identify) is a standard system (EN-62676-4) for defining the ability of a camera to distinguish persons or objects within a covered area. The maximum distance at which a camera/lens combination can meet these criteria is shown below:

**12MP Camera with 3.2 mm lens (112°)**

DORI	DORI definition	Distance	Horizontal width
Detect	25 px/m (8 px/ft)	54 m (167 ft)	160 m (525 ft)
Observe	63 px/m (19 px/ft)	21 m (70 ft)	63 m (207 ft)
Recognize	125 px/m (38 px/ft)	11 m (36 ft)	32 m (105 ft)
Identify	250 px/m (76 px/ft)	5 m (16 ft)	16 m (53 ft)

**12MP Camera with 5 mm lens (70°)**

DORI	DORI definition	Distance	Horizontal width
Detect	25 px/m (8 px/ft)	114 m (374 ft)	160 m (525 ft)
Observe	63 px/m (19 px/ft)	45 m (148 ft)	63 m (207 ft)
Recognize	125 px/m (38 px/ft)	23 m (76 ft)	32 m (105 ft)
Identify	250 px/m (76 px/ft)	11 m (36 ft)	16 m (53 ft)

**12MP Camera with 35 mm lens (9.8°)**

DORI	DORI definition	Distance	Horizontal width
Detect	25 px/m (8 px/ft)	933 m (3061 ft)	160 m (525 ft)
Observe	63 px/m (19 px/ft)	370 m (1214 ft)	63 m (207 ft)
Recognize	125 px/m (38 px/ft)	187 m (590 ft)	32 m (105 ft)
Identify	250 px/m (76 px/ft)	93 m (295 ft)	16 m (53 ft)

**12MP Camera with 50 mm lens (6.8°)**

DORI	DORI definition	Distance	Horizontal width
Detect	25 px/m (8 px/ft)	1347 m (4419 ft)	160 m (525 ft)
Observe	63 px/m (19 px/ft)	534 m (1752 ft)	63 m (207 ft)
Recognize	125 px/m (38 px/ft)	269 m (883 ft)	32 m (105 ft)
Identify	250 px/m (76 px/ft)	135 m (443 ft)	16 m (53 ft)

**12MP Camera with 75 mm lens (4.7°)**

DORI	DORI definition	Distance	Horizontal width
Detect	25 px/m (8 px/ft)	1949 m (6394 ft)	160 m (525 ft)
Observe	63 px/m (19 px/ft)	774 m (2539 ft)	63 m (207 ft)
Recognize	125 px/m (38 px/ft)	390 m (1280 ft)	32 m (105 ft)
Identify	250 px/m (76 px/ft)	195 m (640 ft)	16 m (53 ft)

**Typical applications**

The camera body with a telephoto lens is especially suitable for use in such applications as:

- Stadiums
- Perimeter surveillance
- Airport priority checkpoint monitoring

**Certifications and approvals**

Standards	Type
Emission	EN 55022 Class B (2010), +AC (2011) FCC: 47 CFR 15, class B (2012-10-1)
Immunity	EN 50130-4 (PoE, +12 VDC)* (2011) EN 50121-4 (2006), +AC: (2008)
Alarm	EN 50130-5 Class II (2011)
Safety	EN 60950-1 UL 60950-1 (2nd edition) CAN/CSA-C 22.2 No. 60950-1
Vibration	Camera with 500 g (1.1 lb) lens as per IEC 60068-2-6 (5 m/s <sup>2</sup> , operational)
UHD	SMPTE 2036-2012 Resolution: 3840 x 2160 (UHDTV1) 4K UHD (2160p)
HD	SMPTE 274M-2008 Resolution: 1920x1080

Standards	Type
Color representation	ITU-R BT.2020
ONVIF conformance	EN 50132-5-2; IEC 62676-2-3

\* All systems where this camera is used must comply with this standard as well.

Marks	CE, cULus, WEEE, RCM, EAC and China RoHS
-------	--

Region	Regulatory compliance/quality marks
Europe	CE
USA	UL
	FCC
Canada	CSA

**Installation/configuration notes**

**Controls**

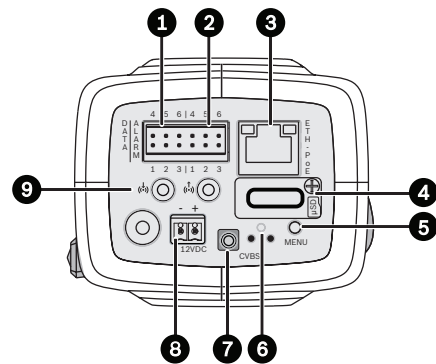

1	Data (RS485/422/232)	6	Reset button
2	Alarm in, alarm out	7	Video out (SMB connector)
3	10/100 Base-T Fast Ethernet	8	Power supply input (12 VDC only)
4	MicroSD card slot	9	Audio in / Audio out
5	Menu button		

**Dimensions**

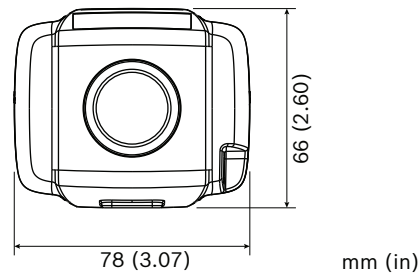

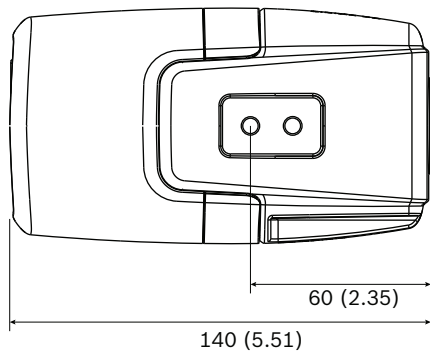
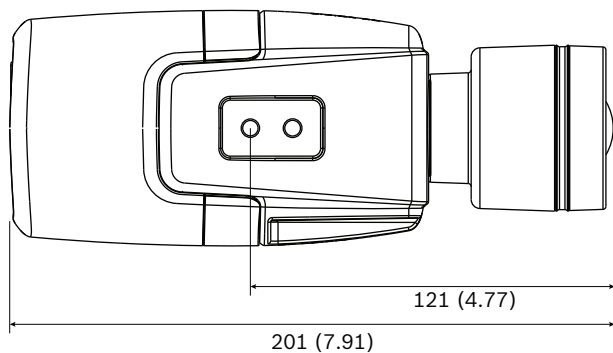
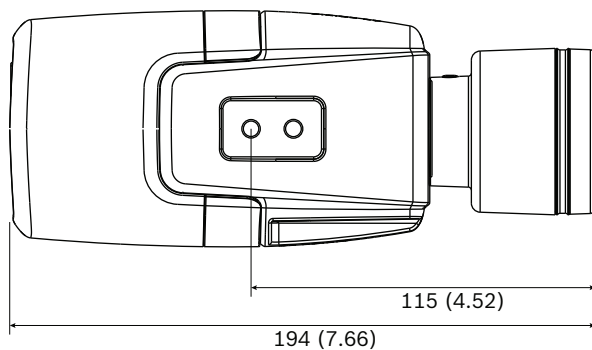
**3.2 mm lens****5 mm lens****Technical specifications****Power**

Power Supply 12 VDC;  
Power-over-Ethernet 48 VDC nominal

Current Consumption 750 mA (12 VDC);  
200 mA (PoE 48 VDC)

Power Consumption 9 W

PoE IEEE 802.3af (802.3at Type 1) Class 3

**Sensor**

Type 1/2.3-inch CMOS

Pixels 12 MP

**Video performance - Dynamic range**

12 MP (4:3) mode 92 dB WDR  
(92+16 dB with IAE)

4K UHD (16:9) mode 92 dB WDR  
(92+16 dB with IAE)

1080p mode 98 dB WDR  
(98+16 dB with IAE)

**Video performance - Sensitivity (permanently attached lens version) (3200K, 89% reflectivity, 30% IRE, F2.45)**

Color (12MP / 4K UHD mode) 0.36 lx

Color (1080p mode) 0.31 lx

Mono (12MP / 4K UHD mode) 0.120 lx

Mono (1080p mode) 0.103 lx

**Video performance - Sensitivity (camera body version) (3200K, 89% reflectivity, 30% IRE, F1.2)**

Color (12MP / 4K UHD mode) 0.11 lx

Color (1080p mode) 0.09 lx

Mono (12MP / 4K UHD mode) 0.037 lx

Mono (1080p mode) 0.030 lx

**Video streaming**

Video compression H.264 (MP); M-JPEG

Streaming Multiple configurable streams in H.264 and M-JPEG, configurable frame rate and bandwidth. Regions of Interest (ROI)

Overall IP Delay Min. 120 ms, Max. 340 ms

GOP structure IP, IBP, IBBP

Encoding interval 1 to 30 [25] fps

Encoder regions Up to 8 areas with encoder quality settings per area

**Video resolution (H x V)**

12MP 4000 x 3000 (at 20 fps)

4K UHD 3840 x 2160 (at 30 fps)

7.3MP 3584 x 2016 (at 30 fps)

1080p HD 1920 x 1080 (at 30 fps)

720p HD 1280 x 720 (at 30 fps)

SVGA 800 x 600



**Video resolution (H x V)**

D1 4:3 (downscaled/ cropped)	704 x 480
480p SD	Encoding: 704 x 480; Displayed: 854 x 480
432p SD	768 x 432
288p SD	512 x 288
240p SD	Encoding: 352 x 240; Displayed: 432 x 240
144p SD	256 x 144

**Video functions**

Day/Night	Color, Monochrome, Auto (adjustable switchover points)
Adjustable picture settings	Contrast, Saturation, Brightness
White Balance	2500 to 10000K, 4 automatic modes, manual mode and measure
Shutter	Automatic Electronic Shutter (AES) Fixed (1/30 [1/25] to 1/15000) selectable Default shutter
Backlight compensation	Off, Auto, Intelligent Auto Exposure
Noise reduction	Intelligent Dynamic Noise Reduction Intelligent Streaming
Contrast enhancement	On/off
Sharpness	Sharpness enhancement level selectable
Intelligent defog	Intelligent Defog automatically adjusts parameters for best picture in foggy or misty scenes (switchable)
Privacy Masking	Eight independent areas, fully programmable
Video Motion Analysis	Intelligent Video Analysis
Scene modes	Nine pre-defined modes
Other functions	Image flip, Pixel counter, Video watermarking, Display stamping, Positioning

**Audio streaming**

Standard	G.711, 8 kHz sampling rate L16, 16 kHz sampling rate AAC-LC, 48 kbps at 16 kHz sampling rate AAC-LC, 80 kbps at 16 kHz sampling rate
Signal-to-Noise Ratio	>50 dB
Audio Streaming	Full-duplex / half duplex

**Input/output**

Analog video out	SMB connector, CVBS (PAL/NTSC), 1 Vpp, 75 Ohm
Audio line in	1 Vrms max, 18 kOhm typical,
Audio line out	0.85 Vrms at 1.5 kOhm typical,
Audio connectors	3.5 mm mono jack
Alarm input	2 inputs
Alarm input activation	+5 VDC nominal; +40 VDC max. (DC-coupled with 50 kOhm pull-up resistor to +3.3 VDC) (< 0.5 V is low; > 1.4 V is high)
Alarm output	1 output
Alarm output voltage	30 VAC or +40 VDC max. Maximum 0.5 A continuous, 10VA (resistive load only)
Ethernet	RJ45
Data port	RS-232/422/485

**Local storage**

Internal RAM	10 s pre-alarm recording
Memory card slot	Supports up to 32 GB microSDHC / 2 TB microSDXC card. (An SD card of Class 6 or higher is recommended for HD recording)
Recording	Continuous recording, ring recording, alarm/ events/schedule recording

**Software**

Unit discovery	IP Helper
Unit configuration	Via web browser or Configuration Manager
Firmware update	Remotely programmable
Software viewing	Web browser; Video Security Client; Video Security App; Bosch Video Management System; Bosch Video Client; or third party software
Latest firmware and software	<a href="http://downloadstore.boschsecurity.com/">http://downloadstore.boschsecurity.com/</a>

**Network**

Protocols	IPv4, IPv6, UDP, TCP, HTTP, HTTPS, RTP/ RTCP, IGMP V2/V3, ICMP, ICMPv6, RTSP, FTP, ARP, DHCP, APIPA (Auto-IP, link local address), NTP (SNTP), SNMP (V1, V3, MIB-II), 802.1x, DNS, DNSv6, DDNS (DynDNS.org, selfHOST.de, no-ip.com), SMTP, iSCSI, UPnP (SSDP), DiffServ (QoS), LLDP, SOAP, Dropbox™, CHAP, digest authentication
Encryption	TLS 1.2, SSL, DES, 3DES

Network	
Ethernet	10/100 Base-T, auto-sensing, half/full duplex
Connectivity	Auto-MDIX
Interoperability	ONVIF Profile S; GB/T 28181

Environmental	
Operating Temperature	-20°C to +50°C (-4°F to 122°F)
Storage Temperature	-30°C to +70°C (-22°F to +158°F)
Operating Humidity	20% to 93% RH
Storage Humidity	up to 98% RH

Optical	
Lens mount	CS mount (C-mount with adapter ring)
Focus control	Motorized back-focus adjustment

Mechanical	
Dimensions (W x H x L)	78 x 66 x 140 mm (3.07 x 2.6 x 5.52 inch) without lens
Weight	690 g (1.52 lb) without lens
Color	RAL 9007 Metallic Titanium
Tripod Mount	Bottom (isolated) and top 1/4-inch 20 UNC
Sustainability	PVC free

## Ordering information

### NBN-80122-CA Fixed camera 12MP

High-performance 12 MP box cameras for intelligent 4K UHD surveillance (without lens) with audio/motion detection and motorized auto-focus.

Order number **NBN-80122-CA**

### EWE-D8IPUL-IW 12mths wrty ext DINION IP ultra 8000 MP

12 months warranty extension

Order number **EWE-D8IPUL-IW**

### Accessories

#### LFF-8012C-D35 Fixed lens, 35mm, telephoto, megapixel

Fixed telephoto megapixel lens ; manual iris; IR corrected; C-mount; 2/3" ; F1.8; 35mm

Order number **LFF-8012C-D35**

#### LFF-8012C-D50 Fixed lens, 55mm, telephoto, megapixel

Fixed telephoto megapixel lens ; manual iris; IR corrected; C-mount; 2/3" ; F2.0; 50mm

Order number **LFF-8012C-D50**

#### LFF-8012C-D75 Fixed lens, 75mm, telephoto, megapixel

Fixed telephoto megapixel lens ; manual iris; C-mount; 1/1.8" ; F1.8; 75mm

Order number **LFF-8012C-D75**

#### LVF-8008C-P0413 Varifocal lens, 4-13mm, 12MP, CS mount

Varifocal megapixel lens; P-iris; CS-mount; 1/1.8" ; F1.5; 4-13mm

Order number **LVF-8008C-P0413**

#### NBN-MCSMB-03M Cable, SMB to BNC, camera-cable, 0.3m

0.3 m (1 ft) analog cable, SMB (female) to BNC (female) to connect camera to coaxial cable

Order number **NBN-MCSMB-03M**

#### NBN-MCSMB-30M Cable, SMB to BNC, camera-monitor/DVR

3 m (9 ft) analog cable, SMB (female) to BNC (male) to connect camera to monitor or DVR

Order number **NBN-MCSMB-30M**

#### UPA-1220-60 Power supply, 120VAC 60Hz, 12VDC 1A out

Power supply for camera. 100-240 VAC, 50/60 Hz In; 12 VDC, 1 A Out; regulated.

Input connector: 2-prong, North American standard (non-polarized).

Order number **UPA-1220-60**

#### UPA-1220-50 Power supply, 220VAC 50Hz, 12VDC 1A out

Power supply for camera. 110-240 VAC, 50/60 Hz In; 12 VDC, 1 A Out; regulated.

Input connector: 2-prong, European Europlug standard (4 mm / 19 mm).

Order number **UPA-1220-50**

#### TC9210U Camera mount, 6", indoor

A universal 6-inch wall/ceiling grid with off-white finish for 4.5 kg (10 lb) max load, incl. T-Bar ceiling clip and wall/ceiling mount flange.

Order number **TC9210U**

#### UHO-HBGS-51 Outdoor housing, blower, 230VAC/35W

Outdoor housing for (230 VAC / 12 VDC) camera with 230 VAC power supply, blower and feed-through cabling.

Order number **UHO-HBGS-51**

#### UHO-HBGS-61 Outdoor housing, blower, 120VAC/35W

Outdoor housing for (120 VAC / 12 VDC) camera. 120 VAC power supply; blower; feed-through cabling

Order number **UHO-HBGS-61**

#### UHO-HBGS-11 Outdoor housing, 24VAC, feed-through

Outdoor housing for (24 VAC / 12 VDC) camera with 24 VAC power supply, blower and feed-through cabling.

Order number **UHO-HBGS-11**



**UHO-POE-10 Outdoor housing, POE + power supply**  
Outdoor camera housing with PoE+ power supply.  
Order number **UHO-POE-10**

**LTC 9215/00 Wall mount with cable feed through, 12"**  
Wall mount for camera housing, cable feed-through,  
30 cm (12 in.)  
Order number **LTC 9215/00**

**LTC 9215/00S Wall mount for UHI/UHO**  
Wall mount for camera housing, cable feed-through,  
18 cm (7 in.)  
Order number **LTC 9215/00S**

**LTC 9219/01 Feed through J mount**  
J-mount for camera housing, 40 cm (15 in.).  
Order number **LTC 9219/01**

**LTC 9210/01 Column mount, 8", 9KG/20lb load**  
Feed-through column mount for 20 cm (8 in.), 9 kg  
(20 lb) maximum load. Light gray finish.  
Order number **LTC 9210/01**

**LTC 9213/01 Pole mount adapter for  
LTC9210,9212,9215**  
Flexible pole mount adapter for camera mounts (use  
together with the appropriate wall mount bracket).  
Max. 9 kg (20 lb); 3 to 15 inch diameter pole; stainless  
steel straps  
Order number **LTC 9213/01**

**NPD-5001-POE Power over ethernet , 15.4W, 1-port**  
Power-over-Ethernet midspan injector for use with PoE  
enabled cameras; 15.4 W, 1-port  
Weight: 200 g (0.44 lb)  
Order number **NPD-5001-POE**

**NPD-5004-POE Power over ethernet, 15.4W, 4-port**  
Power-over-Ethernet midspan injectors for use with  
PoE enabled cameras; 15.4 W, 4-ports  
Weight: 620 g (1.4 lb)  
Order number **NPD-5004-POE**

**UPA-1220-60 Power supply, 120VAC 60Hz,12VDC 1A  
out**  
Power supply for camera. 100-240 VAC, 50/60 Hz In;  
12 VDC, 1 A Out; regulated.  
Input connector: 2-prong, North American standard  
(non-polarized).  
Order number **UPA-1220-60**

#### Services

**EWE-D8IPUL-IW 12mths wrty ext DINION IP ultra  
8000 MP**  
12 months warranty extension  
Order number **EWE-D8IPUL-IW**

#### Represented by:

**Europe, Middle East, Africa:**  
Bosch Security Systems B.V.  
P.O. Box 80002  
5600 JB Eindhoven, The Netherlands  
Phone: + 31 40 2577 284  
emea.securitysystems@bosch.com  
emea.boschsecurity.com

**Germany:**  
Bosch Sicherheitssysteme GmbH  
Robert-Bosch-Ring 5  
85630 Grasbrunn  
Germany  
www.boschsecurity.com

**North America:**  
Bosch Security Systems, Inc.  
130 Perinton Parkway  
Fairport, New York, 14450, USA  
Phone: +1 800 289 0096  
Fax: +1 585 223 9180  
onlinehelp@us.bosch.com  
www.boschsecurity.us

**Asia-Pacific:**  
Robert Bosch (SEA) Pte Ltd, Security Systems  
11 Bishan Street 21  
Singapore 573943  
Phone: +65 6571 2808  
Fax: +65 6571 2699  
apr.securitysystems@bosch.com  
www.boschsecurity.asia